

REPUBLIC OF THE UNION OF MYANMAR

**Myanmar National Electrification Project
Environmental and Social Management Framework**

Volume 1: Main Report

June 27, 2018

Table of Contents

Abbreviations	3
1. Executive Summary	5
2. Background	15
3. Project description	17
4. Institutional Arrangements for Project Implementation	18
5. Relevant Project Environmental and Social Requirements	21
6. Environmental and Social Management Framework Approach	36
7. Description of Typical Infrastructure for Subprojects	39
8. Addressing Environmental and Social Impacts.....	50
9. Monitoring and Evaluation	71
10. Estimated Budget for Environmental and Social Mitigation and Management.....	73
11. Community Engagement, Consultation and Public Disclosure	75
12. Grievance redress mechanism	78
13. Capacity Building and Training Plan.....	81

Abbreviations

ADB	Asian Development Bank
CE	Citizen Engagement
CERC	Contingency Emergency Response Component
CPF	Country Partnership Framework
DFID	Department for International Development
DP	Development Partner
DRD	Department for Rural Development
EMP	Energy Master Plan
ESCOPE	Environmental and Social Code of Practice
ESE	Electricity Supply Enterprise
ESMF	Environmental and Social Management Framework
ESMP	Environmental and Social Management Plan
FGD	Focus Group Discussion
GAD	Township General Administration Department
GoM	Government of Myanmar
GRM	Grievance Redress Mechanism
HH	Household
IBRD	International Bank for Reconstruction and Development
IDA	International Development Association
IEE	Initial Environmental Examination
IFC	International Finance Corporation
IPP	Indigenous Peoples Plan
IPPF	Indigenous Peoples Planning Framework
JICA	Japan International Cooperation Agency
KII	Key Informant Interview
kWh	Kilowatt hour
LV	Low Voltage
MEPP	Myanmar Electric Power Project
MESC	Mandalay Electricity Supply Corporation
MLFRD	Ministry for Livestock, Fisheries and Rural Development
MIGA	Multilateral Investment Guarantee Agency

MOALI	Ministry of Agriculture, Livestock and Irrigation
MONRED	Ministry of Natural Resources and Environmental Conservation
MOEE	Ministry of Electricity and Energy
MOEP	Ministry of Electric Power
MV	Medium Voltage
NEMP	National Electricity Master Plan
NEP	National Electrification Project
OP	Operational Policy
PFM	Public Finance Management
PMO	Programme Management Office
PSIA	Poverty and Social Impact Assessment
PV	Photovoltaic
REAM	Renewable Energy Association of Myanmar
RAP	Resettlement Action Plan
RPF	Resettlement Policy Framework
RBF	Results-Based Financing
SG	Safeguards Specialist
SHS	Solar Home System
SME	Small and Medium Sized Enterprise
SRE	Self-Reliant Electrification
TA	Technical Assistance
UNESCAP	United Nations Economic and Social Commission for Asia and the Pacific
WBG	World Bank Group
Wp	Watt Peak
YESC	Yangon Electricity Supply Corporation

1. Executive Summary

1.1. Description of the National Electrification Project (NEP)

The Myanmar National Electrification Project (the Project), funded by the World Bank through a loan of US\$ 400 million and implemented by the Ministry of Electricity and Energy (MOEE)¹ and the Department of Rural Development (DRD) in the Ministry of Agriculture, Livestock and Irrigation (MOALI)² will aim to: *help increase access to electricity in Myanmar.*

The expected results of the Project include new household connections in urban and rural areas across the country. Also, the project will help establish and support a coordinated sector-wide institutional framework for the implementation of national electrification program, and strengthen institutional capacity of implementing agencies, including both public and private sector active in the grid rollout and off-grid pre-electrification.

The grid roll-out program will not only improve the well-being of the affected population by better lighting, telecommunications and entertainment, but also enable income-generation opportunities and enhanced productivity. Importantly, the program will prioritize connections for health clinics and schools, particularly in poor and vulnerable areas, to maximize developmental impacts.

The project include an off-grid pre-electrification program to directly benefit the poor and vulnerable households by targeting those who reside outside the realm of power grid and are expected to receive grid-based electricity services more than 10 years after the first phase of NEP.

The project includes a Contingency Emergency Response Component (CERC) to allow a rapid response and quick support for emergency recovery and reconstruction in case of an adverse natural disaster event.

Overview of Project Components

Component 1: Grid extension [IDA US\$ 300 million].

This component supports Myanmar's utilities to extend distribution networks and connect communities and households closest to the existing national grid, in line with the National Electrification Plan. The component includes: (a) expansion of existing medium voltage (MV) substations and construction of new MV substations; (b) construction of about 12,900 miles of MV and low voltage (LV) lines, and 772 MVA of MV/LV transformers; and (c) provision of 11,600 community connections (health clinics, schools and other public buildings), 750,000 household connections, and 132,000 public lights. This component will provide International Development Assistance (IDA) financing for power distribution goods and materials (transformers, poles, conductors, insulators, switchgear, materials etc.). The utilities will support installation, with private (community level) contributions at a rate set by the Government, and possible private sector participation.

¹ At the time of project preparation, the agencies for the grid extension component were in the Ministry of Electric Power (MOEP). In the government reorganization of 2016, MOEP was combined with the Ministry of Energy to form the Ministry of Electricity and Energy.

² At the time of project preparation, the DRD was previously in the Ministry of Livestock, Fisheries and Rural Development (MLFRD). In the government reorganization of 2016, MLFRD was combined with the Ministry of Agriculture and Livestock to form the Ministry of Agriculture, Livestock, and Irrigation.

Component 2: Off-grid electrification [IDA US\$ 80 million].

This component targets communities located far beyond the existing national grid and, thus, unlikely to receive grid-based access in the next 10 or more years. The Project funding will be directed to the peripheral States/Regions with social and ethnic tension and conflicts where access to electricity services for all is essential for enhancing social/ethnic cohesion and peace building. Off-grid electrification will be technology neutral, depending on a technology assessment that will be undertaken for target communities. Technologies include solar photovoltaic (PV), mini-hydropower, wind, biomass, and hybrid (e.g. diesel/solar). The Project will support: development of mini-grids based on renewable energy or a hybrid of diesel and renewable energy technologies; and deployment of household solar PV systems in target communities, including households, public institutions (schools, health clinics and other community buildings) as well as public street lighting with cost sharing from villages, IDA grant and government grant. Disbursement of the IDA grant will be results-based and take place after the installation and required services have been delivered and verified in accordance with the guidelines to be detailed in the operational manual.

Component 3: Technical assistance and project management [IDA US\$ 20 million].

This component supports: (a) strengthening of institutional capacity to implement the National Electrification Plan, including capacity building and training of the National Electrification Executive Committee and its Secretariat, capacity building at the Union, State/Region, district, township and village levels and for the private sector; (b) improving the policy and regulatory framework related to electrification; (c) development of an integrated, geographic information system (GIS)-based framework for electrification planning, results monitoring and impact evaluation of the project, building on the existing GIS platform for geospatial least-cost electrification planning; (d) securing technical advice and consulting services on standards, technology assessment and technical design, economic and financial analysis, environmental and social impact management, procurement and financial management; and (e) project management.

Component 4: Contingent Emergency Response [IDA US\$ 0 million].

This “zero component” allows a rapid reallocation of IDA Credit from other components for emergency recovery and reconstruction support in the event of a declared disaster. This component will finance public and private sector expenditure on a positive list of goods and/or specific works, goods, services and emergency operation costs required for emergency recovery. An Operational Manual for this component will detail financial management, procurement, safeguard and any other necessary implementation arrangements, to be submitted to and accepted by the WBG prior to the disbursement for this component of IDA funds.

1.2. Safeguards Assessment of the NEP

A WBG Safeguards Assessment of the NEP was undertaken during project preparation and the following Safeguards Policies were identified as being triggered by the NEP:

- Environmental Assessment OP/BP 4.01
- Natural Habitats OP/BP 4.04
- Physical Cultural Resources OP/BP4.11

- Indigenous Peoples OP/BP 4.10
- Involuntary Resettlement OP/BP 4.12
- Safety of Dams OP/BP4.37

Table 1.1 below provides the summary of the WBG's Safeguards Assessment of the Project.

TABLE 1.1: WBG Safeguards Assessment for The NEP

Safeguard Policies	Triggered?	Explanation
Environmental Assessment OP/BP 4.01	Yes	The project will invest substantially in grid roll-out through the purchase of equipment including for MV-substations (expansion of existing substations and to be built), MV/LV transformers, MV and LV lines, household connections, meters, and off-grid systems including solar PV systems, mini-hydropower, wind, diesel and hybrid systems. Environmental impacts for grid extensions are related to works at substations and the installation of power lines, which for instance may require safe disposal of construction and other waste. These substations are small and impacts are expected to be limited. Off-grid investments could include systems based on diesel generators, wind turbines and small scale hydropower expected not to exceed 1 MW. Possible impacts related for instance to fuel usage and installation of turbines in water streams requiring (environmental) control measures, but investments will not go beyond village level schemes (in principle less than 1 MW) and potential impacts are expected to be limited, localized with few impacts considered as irreversible and mitigation measures can be designed as part of the safeguard instruments to minimize and mitigate impacts during project implementation. In view of this, the project

Safeguard Policies	Triggered?	Explanation
		has been given a Category B classification under OP4.01.
Natural Habitats OP/BP 4.04	Yes	Significant impacts on natural habitats are not expected. However as specific subprojects and their locations are yet to be determined, further information may be needed during implementation to ascertain specific impacts. The ESMF provides specific screening provisions to determine if natural habitats are an issue, as well as what environmental instrument is needed.
Forests OP/BP 4.36	No	Some vegetation clearance will be required for the construction of MV/LV and household connection, but this would be limited and highly localized and would not affect any forestry activities nor require triggering of OP4.36.
Pest Management Op 4.09	No	Myanmar has no practice of pesticide use for maintenance of cleared power line corridors
Physical Cultural Resources OP/BP 4.11	Yes	The policy is triggered to the project as PCRs may be present in subproject sites. Since the exact locations of subprojects are not known at this moment, a guideline for identification of physical cultural resources and

Safeguard Policies	Triggered?	Explanation
		determination of the suitability of the subprojects from the perspective of PCR is provided in the ESMF. The ESMF also includes "Chance Find" procedures for protection of cultural property and contracts for subcontractors will include "Chance Find" procedures.
Indigenous Peoples OP/BP 4.10	Yes	The project is expected to be country-wide and cover all States and Regions, including areas with ethnic minorities who are covered by OP 4.10. Ethnic minorities in Myanmar live mainly, however not exclusively, in the seven States (Kayah, Kayin, Kachin, Chin, Mon, Rakhine, and Shan). Ethnic minority communities would benefit from project activities. However, the project also presents risks and challenges concerning ethnic minorities, particularly in terms of ensuring that they will receive appropriate benefits. Investing in distribution networks and off-grid electrification in conflict or post-conflict areas where ethnic minority organizations provide parallel social services and community infrastructure also poses risks that require a good consultation and project management approach. Since specific project sites will not be identified during project preparation, an Indigenous Peoples Planning Framework has been prepared as part of the ESMF to provide guidance on the screening and planning process for sub-projects, including requirements for site-specific social assessment and consultations and the preparation of site-specific Indigenous Peoples Plans to address particular issues concerning ethnic minorities. The ESMF and

Safeguard Policies	Triggered?	Explanation
		IPPF were informed by the PSIA and consultations undertaken during project preparation following requirement for social impact assessment under OP 4.01 and 4.10.
Involuntary Resettlement OP/BP 4.12	Yes	<p>Since specific project investments are not known by appraisal, it is not possible to rule out that some subprojects would involve involuntary resettlement in the form of land acquisition or loss of other assets. The project will finance distribution networks, including expansion of existing Medium Voltage (MV) substations and construction of new MV substations, (ii) construction of new MV lines, Low Voltage (LV) lines and MV/LV transformers. These investments have a minimal footprint, normally follow existing right-of-way and have some flexibility in terms of specific location to avoid land acquisition or loss of property. However, some land acquisition or loss of assets may be needed for some subprojects, particular in cases where new substations will be financed. Off-grid investments, such as mini-hydro systems may also have minor impacts. Potential impacts and risks in this regard were assessed during project preparation as part of the PSIA. The PSIA also assessed typical arrangements for village based compensation for loss of assets or voluntary donations of land for rural electrification infrastructure undertaken by village cooperatives and other private sector entities. Based on this analysis, a Resettlement Policy Framework was prepared as part of the ESMF to provide guidance on the screening and planning</p>

Safeguard Policies	Triggered?	Explanation
		process for subprojects concerning involuntary resettlement impacts. The RPF also includes a protocol for voluntary land donations.
Safety of Dams OP/BP 4.37	Yes	Project interventions are micro/ mini hydro power installations with capacities less than 1 MW. These are small schemes that normally would not require the construction of dams but weirs to retain water before entering or the off-grid turbine or other small impoundment structures are possible which could be regarded as 'small dams' under this policy and hence it is triggered. These small dams/structures if present in off-grid hydro-power subprojects will require good engineering design as stipulated in OP4.37 and safeguard matters and possible risks, if any, will be assessed and managed under the safeguard requirements of OP4.01, in principle through the ESIA or ESMP, as applicable. 'Large dams' as defined under OP4.37 are far outside the scope and scale of hydropower off-grid subprojects as expected under NEP (average \$40,000-50,000 per subprojects, below 1MW) and hence capacity will not be present with the implementing agencies to review such schemes. Therefore, large dams will not be accepted under the Project and dams/structures that would have a height /water drop of 10m or more will not be considered for Project funding.

Safeguard Policies	Triggered?	Explanation
Projects on International Waterways OP/BP 7.50	No	The project interventions are in nature and in scale not expected to cause any drainage or discharges to surface waters, nor entail any significant usage of surface water for cooling or other purposes, that would affect international waterways.
Projects in Disputed Areas OP/BP 7.60	No	The project interventions are not in disputed areas and will be wholly within the borders of Myanmar.

1.3. Summary of Key Safeguard Issues

No adverse indirect or long term environmental or social impacts are anticipated from project investments, while these are expected to provide positive effects on project beneficiaries and may reduce pollution from fuel-wood used for cooking and candles used for lighting.

Environmental impacts for grid extensions are related to works at substations and the installation of power lines, which for instance may require safe disposal of construction materials, old batteries and other waste. These substations are small and impacts are expected to be limited. Off-grid investments could include systems based on solar, hybrid solar-diesel generators, wind turbines, biomass and small-scale hydropower expected not to exceed 1 MW. Possible impacts related for instance to fuel usage and installation of turbines in water streams would require environmental control measures but investments will not go beyond village level schemes (in principle less than 1 MW) and potential impacts are expected to be limited.

In terms of social impacts, the Bank's Indigenous Peoples (OP 4.10) and Involuntary Resettlement (OP 4.12) safeguard policies are triggered. Adverse impacts, however, are expected to be minor and outweighed by the Project's positive impacts. The type of investments supported by the Project generally have small footprints, normally follow existing right-of-way and have some flexibility in terms of specific location to avoid land acquisition. However, some land acquisition or loss of assets such as trees and standing crops, cannot be ruled out, for instance in relation to expansion of existing and construction of new Medium Voltage (MV) substations.

1.4. The Framework Approach

The geographical scope of the Project is national and it is expected that project implementation will eventually include all 64 districts covering all Regions and States in Myanmar. Urban, peri-urban and rural areas will be included and areas with diverse population groups will be covered, including many areas with ethnic minorities.

Specific investments will be identified during project implementation and from a safeguards perspective the Project is operating within a framework approach. This framework approach includes an Environmental and Social Management Framework (ESMF), inclusive of a Resettlement Policy Framework (RPF) and an Indigenous Peoples Planning Framework (IPPF).

The ESMF provides guidelines for screening all subprojects and all project activities including procurement of goods that would result in investments, determination of requirements for assessment, and preparation of further documentation in accordance with the World Bank safeguards policies including site-specific environmental and social safeguard documents.

The ESMF includes:

- An overview of the environmental and social contexts relevant to the Project.
- Description of the ESMF Approach, including in relation to community engagement, consultation and public disclosure.
- Description of typical infrastructure.
- Procedures for screening environmental and social impacts.
- Guidelines for environmental and social screening of sub-projects.
- Procedures for scoping of environmental and social issues.
- Procedures and guidelines for site-specific safeguard instruments.
- Monitoring and evaluation.
- Estimated budget for environmental and social mitigation and management.
- Capacity building and training plan.

It includes:

- Guidelines for Physical and Cultural Resources, and sample Chance Find Procedures.
- An Indigenous Peoples Policy Framework (IPPF).
- A Resettlement Policy Framework (RPF)
- Brief Example of a ToR for an Environmental and Social Impact Assessment (ESIA)
- Sample Table of Contents for Environmental and Social Safeguard Instruments including ESIA, ESMP, Environmental and Social Code of Practice (ESCoP).

1.5. Private Investors

It is expected that most of the mini-grid subproject investments to be funded by the off-grid component of the project will be implemented by private investors / operators (with their own counterpart-financing) and local communities. All project funded activities, including the subprojects that are implemented by private parties, will be required to comply with the World Bank Safeguard Policies and the project's ESMF. Diversion of safeguarding responsibilities to investors under OP 4.03 will not be considered. This means that the project implementation agencies are also fully responsible for the scoping and reviewing and monitoring of safeguard requirements. For practical reasons, the preparation of the safeguard documents could be transferred to private investors.

As mentioned in the Project Appraisal Document, IFC is envisioning providing Advisory Services to private sector clients in Myanmar that are offering solar electricity products, and to help build a commercial market in central Myanmar. There will be no direct investments made through this proposed NEP project. IFC investment, if any, would be through a separate transaction/ project. The advisory services provided by IFC would be focused on: (1) establishing a broad awareness of quality solar products and arming consumers and distributors with the knowledge to differentiate quality products, and (2) supporting providers of quality solar products to enter the country by lowering barriers to entry and risk of investment by providing market intelligence, facilitating Business to Business relations, supporting distribution networks, and catalyzing access to finance along the supply chain.

2. Background

Myanmar energy consumption is among the lowest in the world. About 70 percent of the population has no access to grid-based electricity services, and the consumption per capita is 160 kWh per annum – twenty times less than the world average. Electricity consumption is growing fast in Myanmar. The peak load demand reached 2,100 mega-watts (MW) in 2014, growing on average 14 percent per annum in the past five years. Electricity shortages and supply disruptions remain prevalent in the country. Accumulated delays in investments in power infrastructure, over-reliance on seasonal hydropower production, together with a rapid increase in electricity demand, which tripled over the last decade, results in large electricity shortages which peaked at about 30 percent of power demand in 2012-2013. The energy sector institutional and regulatory framework is fragmented, particularly in rural electrification.

The World Bank supported National Electrification Project aims to help scale-up access to electricity and support the implementation of the Government's National Electrification Plan (NEP), which aims for universal access to electricity by 2030. The project is an essential element of the joint World Bank Group (WBG) engagement in the energy sector. The sector is one of key drivers of economic growth and poverty reduction in Myanmar, but also a source of public frustration due to lack of access and poor reliability of power supply. The joint WBG program includes on-going and future support for institutional development and capacity building, public and private sector investments in generation, transmission and distribution, hydropower and gas subsectors. Together these sequenced interventions support the WBG twin goals of reducing extreme poverty and increasing shared prosperity in an environmentally and socially sustainable manner.

The Project is funded by the World Bank through an International Development Association (IDA) loan of up to US\$ 400 million over fiscal years 2016-2020, implemented by the Ministry of Electric Power (MOEE) and Ministry of Agriculture, Livestock and Irrigation. The expected results include new household and community electricity connections in urban and rural areas across the country. Also, the project will help establish and support a coordinated sector-wide institutional framework for the implementation of a national electrification program and strengthen the institutional capacity of implementing agencies, including both public and private sector organizations active in the grid rollout and off-grid pre-electrification.

The project is intended to not only improve the well-being of the population by better lighting and telecommunications, but also enable income generation opportunities and enhanced productivity. It will prioritize connections for health clinics and schools to maximize developmental impacts.

The Project is intended to establish the basis for sustained engagement of the WBG in supporting public and private sector investments needed to achieve universal access to electricity in Myanmar by 2030, as well as to strengthen the institutional capacity of GoM. It is expected that the programmatic engagement will comprise three phases with the first phase covering fiscal year 2016-2020. In addition to working with the public and private sector investors, the joint WBG energy team will work closely with all development partners (DPs) active in the power sector (ADB, JICA, KfW, GIZ, DFID, AICS, Norway, Australia, the Rockefeller Brothers Fund, etc.). The NEP is open for other DPs to join with parallel financing. Such a coordinated, sector-wide approach is considered the most

effective to deliver benefits of electrification. It should be noted that all project activities, including those funded from other sources, are subject to the environmental and social safeguards policies of the World Bank.

3. Project description

The NEP has the following components:

Component 1: Grid rollout [up to US\$ 300 million].

The grid component supports the purchase of equipment to extend distribution networks currently operated by the Yangon Electricity Supply Corporation (YESC), the Mandalay Electricity Supply Corporation (MESC), and the Electricity Supply Enterprise (ESE) and connect communities identified in the National Electrification Plan as closest to the existing national grid and thus on the least-cost path for the grid rollout.

This component includes purchase of equipment to:

- Expand existing Medium Voltage (MV) substations and construct new MV substations;
- Construct new or rehabilitate existing MV lines, Low Voltage (LV) lines and MV/LV transformers; and
- Connect households with service lines and meters.

MOEE Project Management Office manages this component, working closely with ESE, MESC, YESC and other partners.

International Development Assistance (IDA) funding will finance procurement of goods (transformers, poles, conductors, cables, meters and auxiliary equipment), which ESE, MESC and YESC will be responsible to install. The International Finance Corporation (IFC) may support private sector participation in installation, in a manner to be determined.

Component 2: Off-grid pre-electrification [IDA US\$ 80 million].

The off-grid component targets those communities located outside the reach of the existing national grid or unlikely to receive grid-based access in the next 10 years. This component will be based on application of mini-grids and household energy systems, including solar photovoltaic (PV) systems, mini-hydropower (not expected to exceed one megawatt), wind, biomass and hybrid systems (e.g. diesel/solar). MOALI is responsible for off-grid rural electrification through its national and sub-national Department for Rural Development (DRD) offices.

Component 3: Capacity building and technical assistance [IDA US\$ 20 million].

This component is to provide Technical Assistance (TA), capacity building and advisory support to Government agencies at all institutional levels (union, state/ region, and district) involved in electrification planning and implementation, technical design, economic and financial analysis, environmental and social impact management, monitoring and evaluation, as well as procurement and financial management.

For the grid component, TA is expected to support development of:

- design standards;
- technical specifications and standard procurement packages;
- project design for the balance of the project;
- project management and implementation support including the management of safeguards compliance; and
- extensive training and capacity building on all planning, engineering and commercial aspects.

For the off-grid component, TA is expected to support development of:

- technical and financial support to local technical advisors who operate at district or township level assisting villages with technology choice decisions, pre-feasibility studies, and project oversight;
- support for feasibility studies and business plans for village mini-grids;
- technical and business development support for companies that manufacture, install, and maintain renewable energy systems;
- support to DRD on technical specifications, procurement documents and bid evaluations, project management and implementation, including the management of safeguards compliance;
- assistance to the financial sector to adopt/adapt mechanisms for consumer and supplier financing
- extensive training and capacity building on all planning, regulatory, policy, engineering and commercial aspects.

Component 4: Contingent Emergency Response [US\$ 0 million].

The objective of this “zero component” is to allow a rapid reallocation of IDA credit proceeds from other components to provide emergency recovery and reconstruction support following an adverse natural disaster event. This component would finance public and private sector expenditure on a positive list of goods and/or specific works, goods, services and emergency operation costs required for Myanmar’s emergency recovery. A Contingency Emergency Response Component (CERC) Operational Manual will be prepared as required and apply to this component, detailing financial management, procurement, safeguard and any other necessary implementation arrangements.

4. Institutional Arrangements for Project Implementation

4.1. Overall NEP Institutional Arrangements

Following the National Electrification Program recommendations, the government has established a National Electrification Executive Committee (NEEC) under the patronage of the Vice President through a decree issued on August 27, 2014. NEEC is chaired by the minister of MOEE and co-chaired by the minister of MOALI. A permanent NEEC Secretariat has been established in MOEE and MOALI, aimed at overseeing NEP Project Management Offices (PMOs), which are responsible for the technical activities carried out by ESE, MESC, YESC and DRD under the Project. The Union-level PMOs

would be responsible for project planning and implementation at the union level, while District PMOs would lead local-level project planning and implementation. Within the MOEE and MOALI (DRD), the Executive Committee, consisting of the MOEE and MOALI Union Ministers and other senior officials, would have overall oversight responsibility of the proposed operation, including the ESMF, and would be informed regularly about overall implementation. The Figure below shows the institutional implementation framework and responsibilities allocated to each level at the time of project planning, when the lead agencies were in MOEP and MLFRD.

Figure 4.1: NEP Institutional Implementation Framework

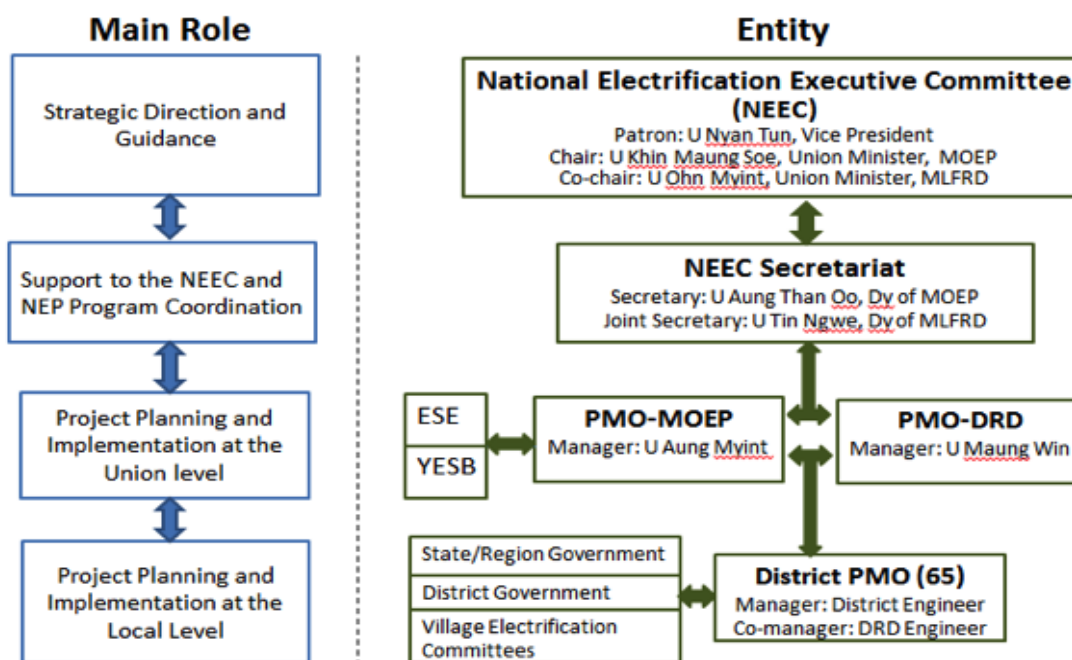

4.2. Off-Grid Program Institutional Arrangements

The institutional framework for the off-grid component is evolving. Figure 4.2 below shows the current proposed implementation framework.

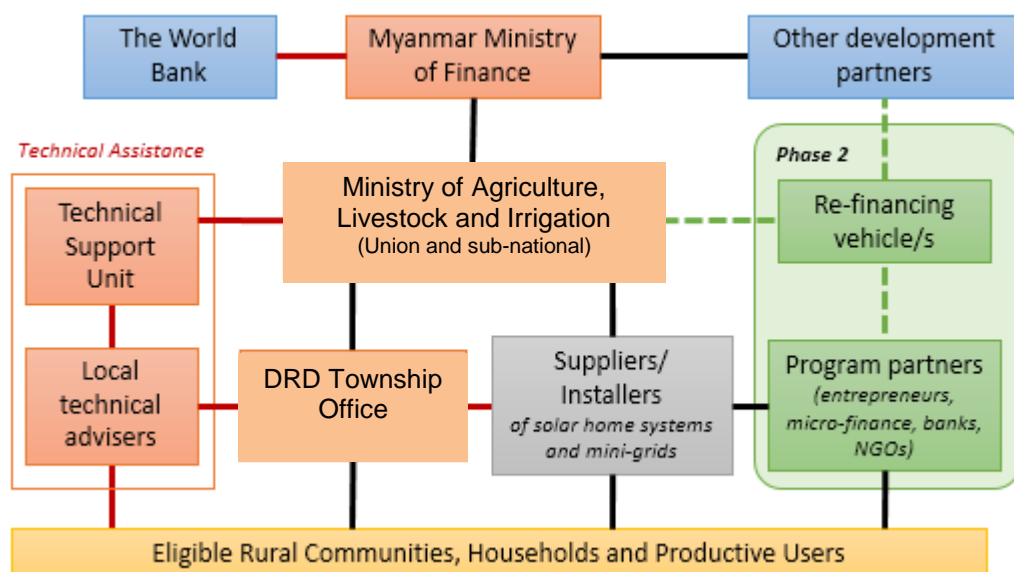
Figure 4.2: Electrification Program Off-grid Component Design Proposal (2015-2020)

At the township and village level, the DRD Township Engineers will provide guidance to village communities and townships in selecting and developing appropriate off-grid electrification solutions. If special assistance is needed to communicate or work with the local communities, Local Technical Advisors can be engaged. The LTAs can be local NGO/CSOs and consultants collaborating with local government (especially but not exclusively DRD staff).

A Technical Support Unit (TSU) at the Union level with international and national expertise will provide technical backstopping to the local technical advisers, as well as support policy and regulatory development. The TSU will also assist the financial sector to adopt/adapt mechanisms for consumer and supplier financing and provide trainings to improve their capacity to assess the credit-worthiness of off-grid electrification projects. For state DRD offices the TSU will develop and disseminate streamlined contracting and procurement processes, support DRD in consumer information campaigns, monitoring and evaluation, and assist in program management. The TSU will assist private sector equipment suppliers and installation companies through capacity building and training on technical as well as business development topics.

4.3. Institutional Arrangements for environmental and social safeguards

The two implementing agencies—MOEE and MOALI (DRD), through their respective central PMOs—will be responsible for the environmental and social performance of the NEP and the subprojects implemented with the support of the NEP. The central PMOs are to be adequately staffed for this purpose with environmental and social safeguards officers). Safeguard staff have been assigned; however these staff, as other ministry staff, have formal positions as Sub Assistant Engineer and Junior Engineer and do not have a background in safeguards. They will therefore be supported by a TA/consultant team that will assist in the implementation of the ESMF requirements while building staff capacity to address safeguard issues.

For each subproject, once it has been identified, the responsible PMO (under MOEE or DRD) will clarify tasks and responsibilities regarding implementation of the specific subproject (e.g. operators, MOEE, local PMOs or villages). The central PMOs will be responsible for reviewing a screening report as prepared by local PMOs or other initiators and prepare draft TOR for ESMP or ESIA and requirements to prepare a Resettlement Action Plan (RAP) and/or Indigenous Peoples Plan (IPP), as needed. Consultation regarding the resulting ESMP or ESIA, and RAP and/or IPP if needed, will be undertaken with the public and stakeholders as required. The documentation will be made available to the public and will also be submitted to the World Bank for review.

The safeguards documents (ESIA, ESMP, etc.) for grid extension are generally prepared by the local PMOs with the support of consultants as needed. For the off-grid component, different approaches are taken for the Solar Home Systems (SHS) and the mini-grid systems. As the SHS has only a few potential low-risk environmental or social impacts, these can be covered through a priori en bloc screening and ex-post verification through post installation verification that the ESCoP for SHS systems has been followed. The mini-grid systems have more potential impacts, and so require more extensive screening and assessment. The private investor/developer and township engineer complete a screening form, which includes documentation of any lands that need to be acquired. After review of these forms, the central PMO will determine if the potential impacts are sufficiently significant that an IEE must be prepared and submitted for approval by the Environmental Conservation Department of the Ministry of Natural Resources and Environmental Conservation (MONREC). The central PMO will also determine if the private investors need to prepare an ESMP (including a waste management plan), RAP, and/or IPP, or if adherence to the ESCoP for the mini-grid with regular monitoring by the township engineer and the safeguards team is sufficient. The central PMO remains responsible for the preparation of the TOR for any safeguards documents required, the review and approval of those documents, and assuring the developers adhere to the safeguards policies.

The central PMOs are responsible for submitting monitoring reports to the World Bank as established in this ESMF and the Project Implementation Manual. Detailed procedures are provided in Section 8. In addition, the NEEC Secretariat will be informed and engaged regularly in the implementation of the ESMF as part of general reporting of NEP implementation.

5. Relevant Project Environmental and Social Requirements

5.1. Environmental Legal and Institutional Framework

The GoM is currently in the process of updating and developing its environmental legal and institutional framework. Numerous challenges remain. Myanmar Environmental policies and laws are mostly sectoral and are gradually transitioning from a nature conservation focus to environmental mainstreaming into the economic and social development of the country.

Sector specific laws - where developed - regulate particular environmental aspects. Therefore, there are gaps in legislation that comprehensively regulate cross-sectoral aspects such as environmental impact assessment, waste management, involuntary resettlement, or particular measures for

vulnerable groups such as ethnic minorities. Sectoral laws also produce overlapping of certain responsibilities.

Myanmar is party to several international treaties, provisions of which are partially incorporated into domestic law.

The legal and institutional gap also extends into administrative and procedural structures, and capacity and resources to enforce such provisions. There is also a need for better coordination between sectoral ministries and between union and local government. The Government acknowledges the importance of environmental protection legislation and enforcement capacity to avoid ecological degradation.

National Environmental Quality (Emission) Standards were issued in December 2015. They include specific provisions on air and water quality as well as noise level standards. The Environmental Quality Standards have been extracted from the International Finance Corporation's Environmental Health and Safety guidelines. An environmental and social impact assessment framework was also issued in Myanmar in December 2015, under the 2012 Conservation Law. Myanmar Electricity Law (27 Oct 2014) states that in accordance with the Law for Environmental Conservation, Myanmar 2012, all electrification projects shall comply to environmental and social assessment work, impact mitigation works, compensation on affected losses, environmental conservation fund raising work shall be carried out by the respective ministry, district and regional government or respective federal government/department. Table 5.1 summarizes the main aspects of the draft EIA rules vis-a-vis the World Bank Operational Policy (OP) 4.01 procedures.

5.2. Environmental Assessment

The National Guidelines for EIA procedure in Myanmar were enacted in late 2015. The comparison between the National EIA procedure guidelines and the World Bank OP/BP 4.01 are shown below in Table 5.1. There is no conflict in the guidelines with the Bank Policies.

Table 5.1: National EIA rules versus OP/BP 4.01 EIA requirements

Issue	EIA Rules	OP 4.01
Screening	<p>Lists projects that require environmental examination including land use change, exploitation of resources or introduction of new species. MONREC shall determine the format and timing of the reports. MONREC will determine the type of environmental assessment required based on the environmental examination</p>	<p>The Bank screens all projects and classifies them into one of four categories (Category A, B, C, and FI), depending on the type, location, sensitivity, and scale of the project and the nature and magnitude of its potential environmental impacts</p>
Triggers	<p>Projects with significant environmental impact</p>	<p>All projects financed by the World Bank. EA process depth will depend on the risk and impacts associated with the Project.</p>
Responsibilities	<p>Project proponent leads the EA process</p>	<p>Borrower leads the EA process</p>
Public participation	<p>For both IEEs and EIAs, the project proponent shall arrange a number of consultations as MONREC deems necessary with local communities, project-affected people, civil society, community organizations, etc. Results of the consultations are to be included in the reports, with the EIAs required to show how concerns are addressed in assessing impacts, designing mitigation measures, and preparing management plans and monitoring plans.</p> <p>For both IEEs and EIAs, MONREC holds public consultations after the reports are submitted, the results of which are provided to the Ministry for final decision on the EIA.</p>	<p>For all Category A and B projects, during the EA process, the borrower consults project-affected groups and local nongovernmental organizations (NGOs) about the project's environmental and social aspects and takes their views into account. The borrower initiates such consultations as early as possible. For Category A projects, the borrower consults these groups at least twice: (a) shortly after environmental screening and before the terms of reference for the EA are finalized; and (b) once a draft EA report is prepared. In addition, the borrower consults with such groups throughout project implementation as necessary to address EA-related issues that affect them.</p>

Issue	EIA Rules	OP 4.01
Disclosure	<p>For both IEEs and EIAs, the project proponent shall disclose at the start of the process all relevant information about the proposed project to the public and civil society through websites, local media, signboards, as well as consultation meetings. For EIAs, additional disclosure shall be done as necessary during the assessment. Within 15 days of submitting the IEE or EIA report to the Department, the project proponent shall disclose the report on websites, through local media, at public meeting places, and at the offices of the project proponent. The Department also discloses the report through its website and in consultation meetings.</p> <p>The decision of the Ministry to approve the IEE / EIA or not is also to be publicly disclosed.</p>	<p>The borrower provides relevant material in a timely manner prior to consultation and in a form and language that are understandable and accessible to the groups being consulted.</p> <p>Any separate Category B report is made available to project-affected groups and local NGOs. Public availability in the borrowing country and official receipt by the Bank of Category A reports, and of any Category B report, are prerequisites to Bank appraisal of these projects.</p> <p>Once the borrower officially transmits the Category A EA report to the Bank, the Bank distributes the summary (in English) to the executive directors (EDs) and makes the report available through its InfoShop. Once the borrower officially transmits any separate Category B EA report to the Bank, the Bank makes it available through its InfoShop.</p> <p>If the borrower objects to the Bank's releasing an EA report through the World Bank InfoShop, Bank staff (a) do not continue processing an IDA project, or (b) for an IBRD project, submit the issue of further processing to the EDs.</p>
Screening	<p>Lists projects that require environmental examination including land use change, exploitation of resources for introduction of new species. MONREC shall determine the format and timing of the reports. MONREC will determine the type of environmental assessment required based on the environmental examination</p>	<p>The Bank screens all projects and classifies them into one of four categories (Category A, B, C, and FI), depending on the type, location, sensitivity, and scale of the project and the nature and magnitude of its potential environmental impacts</p>
EA Content	<p>MONREC determines the content of the EA report, which primarily includes assessment of direct impacts linked to project and description of mitigation measures (environment mitigation plan).</p>	<p>The EA needs to include assessment of project alternatives; cumulative impacts; specific mitigation measures and monitoring activities.</p>

Issue	EIA Rules	OP 4.01
Monitoring	<p>MONREC shall monitor project performance in accordance to the Environmental Management Plan (EMP).</p> <p>The Project proponent shall comply with the EMP and the terms included in the license throughout the lifetime of a project.</p> <p>If found in non-compliance, MONREC shall impose penalties or suspend project construction or operation.</p>	<p>During project implementation, the borrower reports on (a) compliance with measures agreed with the Bank on the basis of the findings and results of the EA, including implementation of any EMP, as set out in the project documents; (b) the status of mitigation measures; and (c) the findings of monitoring programs.</p> <p>The Bank bases supervision of the project's environmental aspects on the findings and recommendations of the EA, including measures set out in the legal agreements, any EMP, and other project documents</p>

5.3. Physical Cultural Resources

The World Bank's policy on physical cultural resources (PCR) OP 4.11 is triggered by the project as PCRs may be present in subproject sites. PCRs are movable or immovable objects, sites, structures, groups of structures, and natural features and landscapes that have archaeological, paleontological, historical, architectural, religious, aesthetic, or other cultural significance. Their cultural interest may be at the local, provincial or national level, or within the international community. Physical cultural resources may be located in urban or rural settings, and may be above or below ground, or under water.

Since the exact locations of the subprojects to be implemented are not known at this moment, a guideline for identification of physical cultural resources and determination of the suitability of the subprojects from the perspective of PCR is provided in Annex 7. The likely impacts to PCR for typical activities of the subprojects are also discussed in that annex. The "Chance Find" procedure for protection of cultural property is presented in Annex 8, following the World Bank Operational Policy OP 4.11 physical cultural resources. Contracts for subcontractors should include "Chance Find" procedures.

The Environmental Conservation Law, enacted in 2012, grants the Ministry of Natural Resources and Environmental Conservation the mandate of "cooperat[ing] with the relevant Government departments and Government organizations in the matters of environmental conservation for perpetual existence of cultural heritage sites and natural heritage sites, cultural monuments and natural areas stipulated under any existing law." Specific regulations and implementation responsibilities are currently being developed.

5.4. Natural habitats

The World Bank's policy on Natural Habitats OP/BP 4.04 is triggered under the NEP. Natural Habitats are land and water areas where: (i) the biological communities are formed largely by native plant and animal species and, (ii) human activity has not essentially modified the area's primary ecological functions. Significant impacts on natural habitats are not expected. However as specific subprojects and their locations are yet to be determined further information may be needed during implementation to ascertain specific impacts. This ESMF provides specific screening provisions to determine if natural habitats are an issue, as well as what environmental instrument is needed if the level of significance of the impacts is unknown. If the impacts to Natural Habitats are considered significant, the particular subproject will not be financed by the project.

As mentioned above, the Environmental Conservation Law enacted in 2012, grants the Ministry of Environment, Conservation and Forestry the mandate concerning matters of environmental conservation for perpetual existence of cultural heritage sites and natural heritage sites, cultural monuments and natural areas stipulated under any existing law. Specific regulations and implementation responsibilities are currently being developed.

5.5. Land Acquisition and Involuntary Resettlement

The project will finance distribution networks, including expansion of existing Medium Voltage (MV) substations and construction of new MV substations, (ii) construction of new MV lines, Low Voltage (LV) lines and MV/LV transformers. These investments have a minimal footprint, normally follow existing right-of-way and have some flexibility in terms of specific location to avoid land acquisition or loss of property. However, some land acquisition or loss of assets may be needed for some subprojects, particularly in cases where new substations will be financed. Off-grid investments, such as mini-hydro systems may also have minor impacts. Since subprojects are not identified until project implementation a Resettlement Policy Framework has been prepared, providing guidance on the screening and planning process for subprojects concerning involuntary resettlement impacts (Annex 8). The RPF includes a protocol for voluntary land donations. The screening procedure and Voluntary Land Donation form is presented in Annex 9. An indicative outline for preparation of an abbreviated Resettlement Action Plan is provided in Annex 10.

The legal framework for land in Myanmar is made up of at least 73 active laws, amendments, orders, and regulations passed under different governments. Analysis suggests that these often overlap, conflict with each other, or do not refer to preceding laws.³ All land belongs to the state under the current legal system, and land users receive certificates from the Settlement Land Records Department.

The legal framework concerning land acquisition in Myanmar is evolving. In January 2016 the GoM issued its National Land Use Policy (NLUP), laying the foundation for a subsequent National Land Law. GoM developed the draft policy since 2012 through a multi-stakeholder consultation process, with the draft presented in 2014 and revised after public consultations in 2014 and 2015. The policy

³ Land Use Policy Reform in Burma: Engaging Stakeholders and Regional Lessons", 24 March, 2014, United States Agency for International Development, <http://usaidlandtenure.net/commentary/2014/03/land-use-policy-reform-burmaengaging-stakeholders-regional-lessons>

aims to strengthen the government's mechanisms for handling land acquisition, compensation, relocation, and restitution. However, as of mid-2018, the government has yet to propose a new National Land Law.

The 1894 Land Acquisition Act remains the legal basis for land acquisition in Myanmar – however different regulations apply for different types of land and there are no comprehensive regulations related to land use rights, transfer of rights, land acquisition or resettlement issues. Section 23 determines suitable amounts of compensation to be made for affected persons when the land is acquired by the government. Detailed descriptions and procedures are mentioned in the Land Acquisition Directions. The Act and associated Rules (Land Acquisition Rules, 1932) further outline relevant procedures including for notice periods, objections of interested persons to acquisition, methods of valuation of land, temporary land occupation, court processes and appeals and acquisition of land for companies.

The Farmland Act of 2012 determines land use rights for farmland and granting of land use rights to eligible farmers. It allows the right to sell, mortgage, lease, exchange and gift whole or a part of the right to use the farmland. The law determines the formation as well as roles/responsibilities of farmland administrative bodies at various levels. The Farmland rules determine procedures such as the application for farmland registration and obtaining land use certificates; application of transfer of farmlands for other purposes; and indemnities and compensation.

The current national legislation regarding compensation for loss of land and assets, as described above, includes some measures similar to key principles of World Bank OP 4.12 on Involuntary Resettlement. However, OP 4.12 is more detailed and includes a number of requirements not found in national legislation, such as preparation of a Resettlement Action Plan (RAP), consultations and public disclosure. For the NEP, all requirements of OP 4.12 apply and the Government of Myanmar agrees to waive any legal or regulatory provisions in contradiction to the requirements of OP 4.12 as established in the Resettlement Policy Framework (RPF), annexed to this ESMF, and to take actions necessary to ensure full and effective implementation of RAPs prepared in accordance with the RPF and OP 4.12. More description of the national legal framework is found in the RPF and should the draft Land Law be approved during project implementation a more detailed comparison to OP 4.12 should be undertaken and the RPF may be changed in agreement between GoM and the World Bank.

5.6. Ethnic Minorities

The Government recognises 135 separate ethnic groups referred to within the Constitution as "*national races*." Major groups include Burman/Bamar, Shan, Karen/Kayin, Kachin, Chin, Rakhine, Mon and Kayah. The largest ethnic group is the Bamar (Burmese) people comprising about two-thirds of the population and who reside predominantly in the central and delta (seven) regions. Other *national races* or *ethnic minorities* account for about one third of the population and live mainly within the seven states (although not exclusively). Aside from the 14 States and Regions, there are five self-administered zones: Naga (Sagaing Region); Danu (Shan State); Pa-O (Shan State); Pa Laung (Shan State); and Kokang (Shan State). There is also one self-administered division: Wa (Shan State). These six self-administered sub-national units are recognised in the 2008 Constitution (section 56) and are the result of earlier ceasefire agreements. Myanmar's ethnic minorities make up

an estimated 30 – 40 per cent of the population, and ethnic states occupy around 57 per cent of the total land area along most of the country's international borders.⁴

The 2008 Constitution provides equal rights to the various ethnic groups included in the term *national races* and a number of laws and regulations aim to preserve their cultures and traditions.⁵ Myanmar national law sets out rights of ethnic races or nationalities to representation in State parliament.⁶ The National Races Protection Law, of February 2015, contains sections guaranteeing minorities the right to study their language and literature, practice other elements of their culture and maintain their traditions.⁷ The National Land Use Policy recommends the recognition of traditional land use systems of ethnic minorities be provided in the new land law, with a suggested process of determining the type and area of those traditional lands; though as of mid-2018 the new law that would formally recognize these traditional rights has not been passed.

The GoM generally uses terms other than 'indigenous peoples.' In September 2007, Myanmar endorsed the United Nations Declaration on the Rights of Indigenous Peoples, which among other things provides indigenous peoples the right to free and prior informed consent and notes that "States shall consult and co-operate in good faith with the Indigenous Peoples concerned through their own representative institutions in order to obtain Free and Prior Informed Consent prior to approval of any project affecting their land or territories."

Since the project is countrywide, covering all States and Regions, it will include areas with ethnic minorities or national races; thus, the World Bank's Indigenous Peoples policy (OP 4.10) applies in general to the 135 officially recognized *national races*, except for the majority Bamar group. This is especially so for the off-grid components which cover more remote areas of the country.

While ethnic minority communities would benefit from project activities, the project also presents risks and challenges concerning ethnic minorities, particularly in terms of ensuring that they will receive appropriate benefits. Investing in distribution networks and off-grid electrification in conflict or post-conflict areas where ethnic minority organizations provide parallel social services and community infrastructure also poses risks that require a good consultation and project management approach. Since specific project sites are identified as the project is being implemented, these issues will be assessed and addressed at the subproject level. An Indigenous Peoples Planning Framework (IPPF) has been prepared as part of the ESMF to provide guidance on the screening and planning process for subprojects, including requirements for site-specific social assessment and consultations and whether site-specific Indigenous Peoples Plans are required to address particular issues concerning ethnic minorities (See Annex 9).

5.7. Policy and Institutional Framework Regarding Women

Key clauses within the Constitution of Myanmar that relate to women include:

⁴<http://www.tni.org/sites/www.tni.org/files/download/accesdenied-briefing11.pdf>, accessed 09 March 2015

⁵Republic of the Union of Myanmar, Ministry of Health, *Myanmar Essential Health Services Access Project Community Engagement Planning Framework*

⁶<http://www.myanmar-responsiblebusiness.org/pdf/SWIA/Oil-Gas/11-Ethnic-Minorities-Indigenous-Peoples.pdf>, accessed 09 March 2015

⁷ Myanmar Times, 23 January 2015, MPs prepare to debate proposed law on ethnic rights

- Clause 348: “The Union shall not discriminate any citizen of the Republic of the Union of Myanmar, based on race, religion, official position, status, culture, sex and wealth”.
- Clause 349: Citizens shall enjoy equal opportunity in carrying out the following functions:(a) public employment;(b) occupation;(c) trade; (d) business; (e) technical know-how and vocation;(f) exploration of art, science and technology.
- Clause 350: Women shall be entitled to the same rights and salaries as that received by men in respect of similar work.

Myanmar is a signatory to the Convention on the Elimination of All Forms of Discrimination against Women (CEDAW) (1997), and is committed to international policy initiatives to improve the situation of women, including the Millennium Declaration, the Beijing Declaration and Platform for Action (BPfA), and the International Conference on Population and Development (ICPD). The Association of South East Asian Nations (ASEAN) has established the ASEAN Commission on Protection and Promotion of the Rights of Women and Children (ACWC), and the ASEAN Committee on Women (ACW), of which Myanmar is a member.

The Ministry of Social Welfare, Relief and Resettlement, through the Department of Social Welfare, carries out social welfare services through preventative, protective and rehabilitative measures, with special attention to children, youth, women, persons with disabilities, and elderly persons. The Department of Social Welfare provides welfare services to vulnerable groups on the basis of social integration strategies.

The Myanmar National Committee for Women’s Affairs (MNCWA) has prepared a National Strategic Plan for the Advancement of Women (2013-2022), whose objective is that, “All women in Myanmar are empowered and able to fully enjoy their rights with the support of the Government of the Republic of the Union of Myanmar. Enabling systems, structures and practices are created for the advancement of women, gender equality, and the realization of women’s rights”. Of relevance, the 12 Priority Areas for the Plan include: women and livelihoods; women education and training; women and health; women and the economy; and women and the environment.

5.8. Overview of World Bank Safeguard Policies Triggered

The proposed NEP triggers the following World Bank policies: Environmental Assessment (OP 4.01); Natural Habitats (OP 4.04); Physical Cultural Resources (OP 4.11); Involuntary Resettlement (OP 4.12) and Indigenous Peoples (OP 4.10). The World Bank has identified NEP as Category B as per OP/BP 4.01, as the safeguard impacts of the type of subprojects supported are site-specific, few are irreversible and mitigation measures can be designed to minimize and mitigate impacts during project implementation (see Table 5.2 for details). In addition to the mitigation measures described in this ESMF, a screening process is included to prevent the execution of subprojects with significant negative environmental or social impacts.

The Project includes strengthening of institutional capacity to implement the National Electrification Plan and technical assistance to improve policy and regulatory framework related to electrification (Component 3). These TA activities would not have direct adverse safeguard impacts; they will not lead to the completion of technical or engineering designs, or other outputs in preparation for the

construction of physical infrastructure or other activities with potentially significant physical impacts. However, advice on policies may have implications concerning environmental and social aspects relevant to the Bank's safeguard policies, and provide an opportunity to integrate environmental and social objectives in policy advice. Bank-financed TA activities with safeguard implications will provide advice consistent with the Bank's safeguard policies following the Interim Guidelines on the Application of Safeguard Policies to Technical Assistance (TA) Activities in Bank-Financed Projects and Trust Funds Administered by the Bank. Moreover, component 3 will provide capacity building for implementing agencies concerning environmental and social concerns.

Table 5.2 : WBG Safeguards Assessment for The NEP

Safeguard Policy	Triggered?	Explanation
Environmental Assessment	Yes	<p>The project will invest substantially in grid roll-out through the purchase of equipment including for MV-substations (expansion of existing substations and new), MV/LV transformers, MV and LV lines, household connections, meters, and off-grid systems including solar PV systems, mini hydropower, wind, diesel and hybrid systems. Environmental impacts for grid extensions are related to works at substations and the installation of power lines, which for instance may require safe disposal of construction, old equipment and other waste. These substations are small and impacts are expected to be limited. Off-grid investments could include systems based on diesel generators, wind turbines and small-scale hydropower expected not to exceed 1 MW. Possible impacts related for instance to fuel usage and installation of turbines in water streams would require environmental control measures but investments will not go beyond village level schemes (in principle less than 1 MW) and potential impacts are expected to be limited.</p> <p>In view of this, the project has been given a Category B classification under OP4.01. This ESMF provides for screening investments into the above described limited scope and avoiding significant impacts. Arguably, the single type of projects that could challenge the Category B classification could be the off-grid mini hydro-systems. Given that these systems remain below 1 MW, without a</p>

Safeguard Policy	Triggered?	Explanation
		<p>need for building significant reservoirs or land-take, it is not expected that these systems would require a different categorization.</p> <p>The Project will focus on building the capacity of staff, with strong mechanisms and procedures in place to screen, assess, plan and monitor the implementation of subprojects. This capacity will also be required to support applicants with the efficient preparation of proposals for subprojects. The implementation stage of the Project will also include the design of subprojects based on approved application for subprojects. Given this need to establish institutional arrangements and build implementation capacity first, all subprojects and equipment purchases will be determined during project implementation, this framework provides for the modalities of selection and implementation of equipment purchases and implementation of subprojects. The framework includes a Resettlement Policy Framework and an Indigenous Peoples Planning Framework. This ESMF also includes guidance in the form of an Environmental and Social Code of Practice, and health and safety standards to be followed during project implementation based on the World Bank Group's Environmental, Health and Safety (EHS) Guidelines for Power Transmission and Distribution and including provisions for beneficiaries and worker health and safety. The ESMF provides guidelines for screening of all subprojects including procurement of goods that would result in investments, determination of requirements for assessment and preparation of further documentation in accordance with the World Bank safeguard policies including site-specific environmental and social management plans (ESMPs), Environmental and Social Impact Assessments (ESIA) and the implementation and monitoring of these. When needed, the ESMPs will include a Resettlement Action Plan and Indigenous Peoples Plan as described below.</p>

Safeguard Policy	Triggered?	Explanation
		<p>Social impacts have been assessed through the PSIA which has taking place in two phases. The first phase focused on generating an overall understanding of access to electricity (barriers to access in rural and urban areas and for poor and marginalized households in particular), uses of electricity, quality of service and affordability of new tariffs of April 2014. The PSIA phase 1 report was finalized in December 2014. The second phase (PSIA2) was initiated in January. The preliminary PSIA to inform this ESMF is available as a separate document. It analyzes potential project impacts and mitigations measures in view of OP 4.01, OP 4.10 and OP 4.12.</p> <p>Given the current lack of capacity with the implementing agencies and other parties that are expected to implement the project and investments in sub projects, a comprehensive safeguards capacity building program is required to prepare designated PMO staff and others for project implementation. PMO staff has received on the job training preparing this ESMF and undertaken part of the PSIA phase 2 analysis and consultations working alongside international and local safeguard consultants. This ESMF includes a training program for PMO staff and other project counterparts; it also includes technical assistance to assist the PMOs during project and ESMF implementation.</p> <p>In addition to subprojects that are implemented by ESE, MESC and YESC, it is expected that part of the subprojects' investments to be funded by the Project will be implemented by private investors / operators and local communities. The ESMF includes procedures for screening, impact assessments, planning, implementation and monitoring that differentiate for the various categories of implementing entities. Since the Project in principle will only finance the purchase of goods, the ESMF procedures considers that these investments will be matched with funding from investors and local communities, as applicable. All project funded activities, including</p>

Safeguard Policy	Triggered?	Explanation
		subprojects that are implemented by private parties, will be required to comply with the World Bank Safeguard Policies and this ESMF. ⁸
Natural Habitats OP/BP 4.04	Yes	Significant impacts on natural habitats are not expected. However as specific subprojects and their locations are yet to be determined further information may be needed during implementation to ascertain specific impacts. This ESMF provides specific screening provisions to determine if natural habitats are an issue, and what environmental instrument is needed if the level of significance of the impacts is unknown. If the impacts were to be considered significant the Project will not finance the particular subproject.
Forests OP/BP 4.36	No	This policy is not triggered as the Project is not expected to have impacts on the health and quality of forests, nor affect the rights and welfare of people and their level of dependence upon or interaction with forests, nor aims to bring about changes in the management, protection or utilization of natural forests or plantations. This ESMF provides for screening investments to avoid impacting the health and quality of forests.
Pest Management OP 4.09	No	This policy is not triggered. It is not practice in Myanmar to include pesticides in maintaining the right of way under transmission lines.
Physical Cultural Resources OP/BP 4.11	Yes	Since specific project investments are not known, it is not possible to rule out the presence of physical cultural resources. This ESMF provides for screening investments during project implementation and, when needed, including requirements as part of environmental assessment and ESMP, to avoid impacting physical cultural

⁸Diversion of safeguard responsibilities to investors under the World Bank's Operational Policy on (OP 4.03) is not foreseen as the capacity concerning safeguards is not expected to be in place. Should this change during project implementation the ESMF may be revised in agreement between the World Bank and GoM.

Safeguard Policy	Triggered?	Explanation
		resources.
Indigenous Peoples OP/BP 4.10	Yes	<p>The project is country-wide and covers all States and Regions, including areas with ethnic minorities who are covered by OP 4.10. Ethnic minorities in Myanmar live mainly, however not exclusively, in the seven States (Kayah, Kayin, Kachin, Chin, Mon, Rakhine, and Shan). Ethnic minority communities would benefit from project activities. However, the project also presents risks and challenges concerning ethnic minorities, particularly in terms of ensuring that they receive appropriate benefits. Investing in distribution networks and off-grid electrification in conflict or post-conflict areas where ethnic minority organizations provide parallel social services and community infrastructure also poses risks that require a good consultation and project management approach. Since specific project sites will not be identified during project preparation, the ESMF include an Indigenous Peoples Planning Framework to guide the screening and planning process for subprojects, including requirements for site-specific social assessment and consultations and the preparation of site-specific IPPs to address particular issues concerning ethnic minorities. Electrification of the villages near the Thaton Power Station in Mon State, supported by the World Bank-financed Myanmar Electric Power Project ,is a priority for electrification under the NEP Project once the power plant is upgraded (scheduled for 2017). An Indigenous Peoples Plan for Thaton and other subprojects in areas with ethnic minorities will be prepared during project implementation once site-specific information will become available with the investment proposals.</p> <p>A Poverty and Social Impact Assessment was undertaken during project preparation to assess potential project impacts and risks as well as issues pertaining to accessibility, affordability, vulnerability, poverty, gender, productive uses and benefits related to electricity. The PSIA included social assessment requirements of OP 4.10, as well as OP 4.01, and has informed project design, the ESMF and the IPPF to address any particular issues</p>

Safeguard Policy	Triggered?	Explanation
		concerning ethnic minorities. Thaton District and the villages near the power station supported by the Myanmar Electric Power Project was covered by the PSIA. Consultations were also undertaken in select villages in Chin and Shan States, and with civil society organizations, including ethnic minority organizations. The preliminary PSIA to inform this ESMF is available as a separate document.
Involuntary Resettlement OP/BP 4.12	Yes	Since specific project investments are not known by appraisal, it is not possible to rule out that some subproject would involve involuntary resettlement in the form of land acquisition or loss of other assets. The Project will finance distribution networks, including expansion of existing Medium Voltage (MV) substations and construction of new MV substations, (ii) construction of new MV lines, Low Voltage (LV) lines and MV/LV transformers. These investments have a minimal footprint, normally follow existing right-of-way and have some flexibility in terms of specific location to avoid land acquisition or loss of property. However, according to the PSIA some land acquisition or loss of assets may be needed for some subprojects, particular in cases where new substations will be financed or required for distribution systems financed by the project. Off-grid investments, such as mini-hydro systems may also have minor land acquisitions impacts. The PSIA also assessed common arrangements for village based compensation for loss of assets or voluntary donations of land for rural electrification infrastructure undertaken by village cooperatives and other private sector entities. A Resettlement Policy Framework has been prepared as part of the ESMF to provide guidance on the screening and planning process for subprojects concerning involuntary resettlement impacts and includes a protocol for voluntary land donations.
Safety of Dams OP/BP 4.37	Yes	Project interventions are micro/ mini hydro power installations with capacities less than 1 MW. These are small schemes that normally would not require the construction of dams but weirs to retain water before entering or the off-grid turbine or other small

Safeguard Policy	Triggered?	Explanation
		impoundment structures are possible which could be regarded as 'small dams' under this policy and hence it is triggered. These small dams/structures if present in off-grid hydro-power subprojects will require good engineering design as stipulated in OP4.37 and safeguard matters and possible risks, if any, will be assessed and managed under the safeguard requirements of OP4.01, in principle through the ESIA or ESMP, as applicable. 'Large dams' as defined under OP4.37 are far outside the scope and scale of hydropower off-grid subprojects as expected under NEP (average \$40,000-50,000 per subprojects, below 1MW) and hence capacity will not be present with the implementing agencies to review such schemes. Therefore, large dams will not be accepted under the Project and dams/structures that would have a height /water drop of 10m or more will not be considered for Project funding.
Projects on International Waterways OP/BP 7.50	No	The project interventions are small in nature and in scale not expected to cause any drainage or discharges to surface waters, nor entail any significant usage of surface water for cooling or other purposes, that would affect international waterways.
Projects in Disputed Areas OP/BP 7.60	No	The project interventions are not in disputed areas as defined by OP 7.60 and will be wholly within the borders of Myanmar.

6. Environmental and Social Management Framework Approach

6.1. Framework Approach

As the specific infrastructure and location of the grid extension and off grid electrification subprojects as well as specific technical assistance are not identified at this stage, a framework approach has been adopted to assess the potential environmental and social impacts and risks of the NEP. This Environmental and Social Management Framework (ESMF) provides general policies, guidelines and procedures to prevent or minimize environmental and social impacts for all project components and subprojects.

The ESMF provides guidance as follows:

- Subprojects (e.g., distribution line, substations, solar panels, mini-grids) and technical assistance are formulated considering potential environmental and social issues, especially of those people who would be directly benefited or impacted by the proposed project;
- Subprojects and technical assistance are designed considering the unique socio-cultural and environmental situation prevailing in the areas where the specific subproject would be implemented;
- Possible environmental and social impacts of subproject activities during both construction and operational phases are identified during project formulation and design, and appropriate mitigation/enhancement measures are devised and a monitoring plan prepared, as part of the overall environmental and social management instruments;
- Environmental and Social Management Instruments such as Environmental and Social Management Plans (ESMP), Resettlement Action Plans (RAPs), Indigenous Peoples Plans (IPP) and Environmental and Social Codes of Practices (ESCoP) and procedures to prepare and follow these instruments; and
- Project activities comply with the relevant World Bank Group Safeguard Policies, as well as National Regulation. As Myanmar legislative framework is expected to continue developing throughout the life of the Project, appropriate gap analysis will be carried out to fill the possible gaps between National Regulation and World Bank Group Safeguard Policies.

Under the Project, the two implementing agencies – MOEE and DRD, through their respective PMOs – are responsible for identification and screening of subprojects and their adequate environmental and social performance. More particularly, the PMOs will prepare a subproject description (see section 5), carry out an environmental/social screening and will assess the requirements for subsequent environmental and social management instruments (e.g. ESCoP, ESMP, IEE, RAP, IPP).

In general, the environmental and social due diligence to be carried out by the PMOs for each subproject includes: (i) subproject description, (ii) identification of subproject area of influence; (iii) establishment of an environmental and social baseline against which impacts of the proposed subproject would be evaluated; (iv) assessment and evaluation of environmental and social impacts and risks of the subproject both during construction and operation; (v) carrying out public consultations, when applicable, and disclosure; and (vi) application of Environmental and Social Code of Practice (ESCoP)⁹ and/or identification of mitigation measures and preparation of environmental and social management plans (ESMP, RAP, IPP, as needed) including implementation arrangements, monitoring requirements, budgeting and grievance redress mechanism. This ESMF presents detailed guidelines for carrying out each of these activities.

The Project and this ESMF supports a consultative process with local communities and other relevant stakeholders. It supports decision making by allowing the public access to information on

⁹ Environmental and Social Codes of Practice for each type of subproject (see Annexes 15 to 17) have been prepared to manage minor environmental negative impacts associated with NEP subprojects. The ESCoP sets out measures to be taken to avoid or mitigate environmental and social impacts during planning, preparation, construction and operation. The ESCoP will be incorporated into bidding documents and/or contracts.

environmental and social aspects of the project and involving local communities in preparation of subprojects and their safeguard instruments when required, as included in World Bank Safeguard Policies, including for Environmental Assessment, Involuntary Resettlement and Indigenous Peoples (see Section 11 for details).

7. Description of Typical Infrastructure for Subprojects

7.1. Grid Extension

7.1.1. Expansion of Existing MV Substations and Construction of MV (33/11 KV) Substation

The Project is financing equipment that will be used to expand existing MV substations and construct new MV substations. Then from these substations, distribution lines can be installed that can connect the national grid via distribution line infrastructure to a transformer and to a household. Existing substations will be expanded by: (i) Installing an additional set of relevant Transformer (for example installing an additional 10 MVA Transformer to a 33/11 KV Substation with a 10 MVA Capacity); (ii) Providing a set of substation extension Protection System (for example installing a 33 KV Protection System to a 33/11 KV Substation with a 20 MVA Capacity)

Figure 7.1 Line Diagram of different units of a 33/11 KV substation

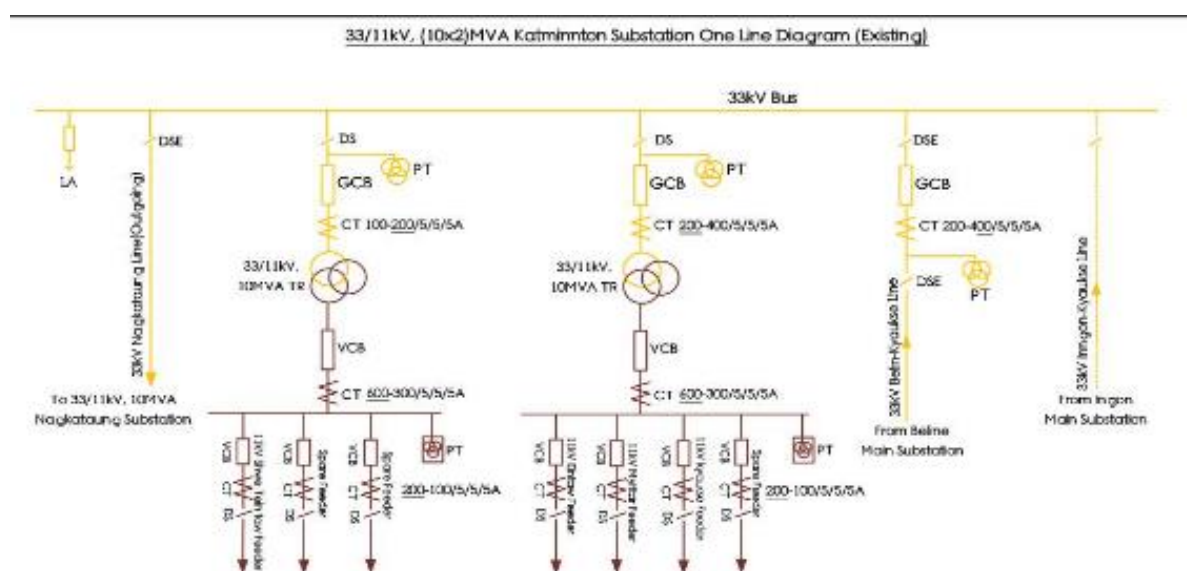

Once land for the new Substation or its expansion is selected and acquired, the soil has to be investigated to assess its suitability for constructing infrastructure such as staff housing, control buildings and switch yard. Each new substation needs an estimated 1.2 hectare (3 acres). The civil construction works include the construction of the control room (building) along with the construction of the foundations for different equipment, followed by the construction of the boundary wall and the guard room.

After manufacturing and shipment of the 33 KV auto reclosers (disconnecting switch DS), 11 KV auto reclosers and the 33/11KV single phase transformers, these are installed in the switchyard within the Substation complex. The incoming line, switchgears, transformers and outgoing lines are connected

by 33 KV, 11 KV and 0.4KV cables along with the control cables both inside and outside the control building.

Safeguard measures such as lightening arrestors as well as earthing cables need to be installed to prevent damage of equipment due to lightening during a storm event. The terminal structures for the 33 KV and 11 KV lines need to be constructed within the premises of the Substation for final connectivity with the distribution system.

7.1.2. Construction of 33 KV and 11 KV Distribution Lines, LV lines and MV/LV transformers

The first step in constructing the distribution lines is conducting a survey of the probable routes. A topographical survey is often conducted along the selected routes to assess the need for ground modification and/or preparation. Spun Pre-stressed Concrete (SPC) poles are erected along the selected routes at designated intervals. The height of the poles depends on the supply power. Usually, 12 m poles are used for 33 KV distribution lines, which simultaneously extend the 11KV and 0.4 KV Lines. H- Poles are used to mount 11/0.4 KV transformers from which three phase lines are extended to the domestic users. Figure 7.2 below shows a schematic diagram of such an H-pole with the dual lines for 33 KV and 11 KV power distributions.

After procuring, the SPC Poles are stacked along the route at designated storage areas beside the road. A hydraulic jack and drilling rig equipped truck is generally used to install the SPC Poles. First, the existing short poles are pulled out and the exposed hole is enlarged and deepened by the truck-mounted drilling rig. The 12m SPC Poles (with two concrete blocks at the bottom) are inserted with the help of the hydraulic elbow-jack mounted on the truck. Following erection of poles, assortments are installed for extending the 33 KV, 11 KV and 0.4 KV lines. A copper wire is passed through the poles into the ground to secure earthing. Lightening arrestor is installed at the top. Drop fuses are mounted on top of the H-poles to prevent short-circuiting.

Typical safeguard measures for this type of infrastructure include clearing of vegetation under the power line system ROW (Right of Way), regular monitoring and surveillance of the Power Lines to check for any risk of fire or undesirable accidents and providing necessary repairs and maintenance work regarding the power lines.

Figure 7.2: Typical H-Pole Arrangement along 33 KV and 11 KV Distribution Lines

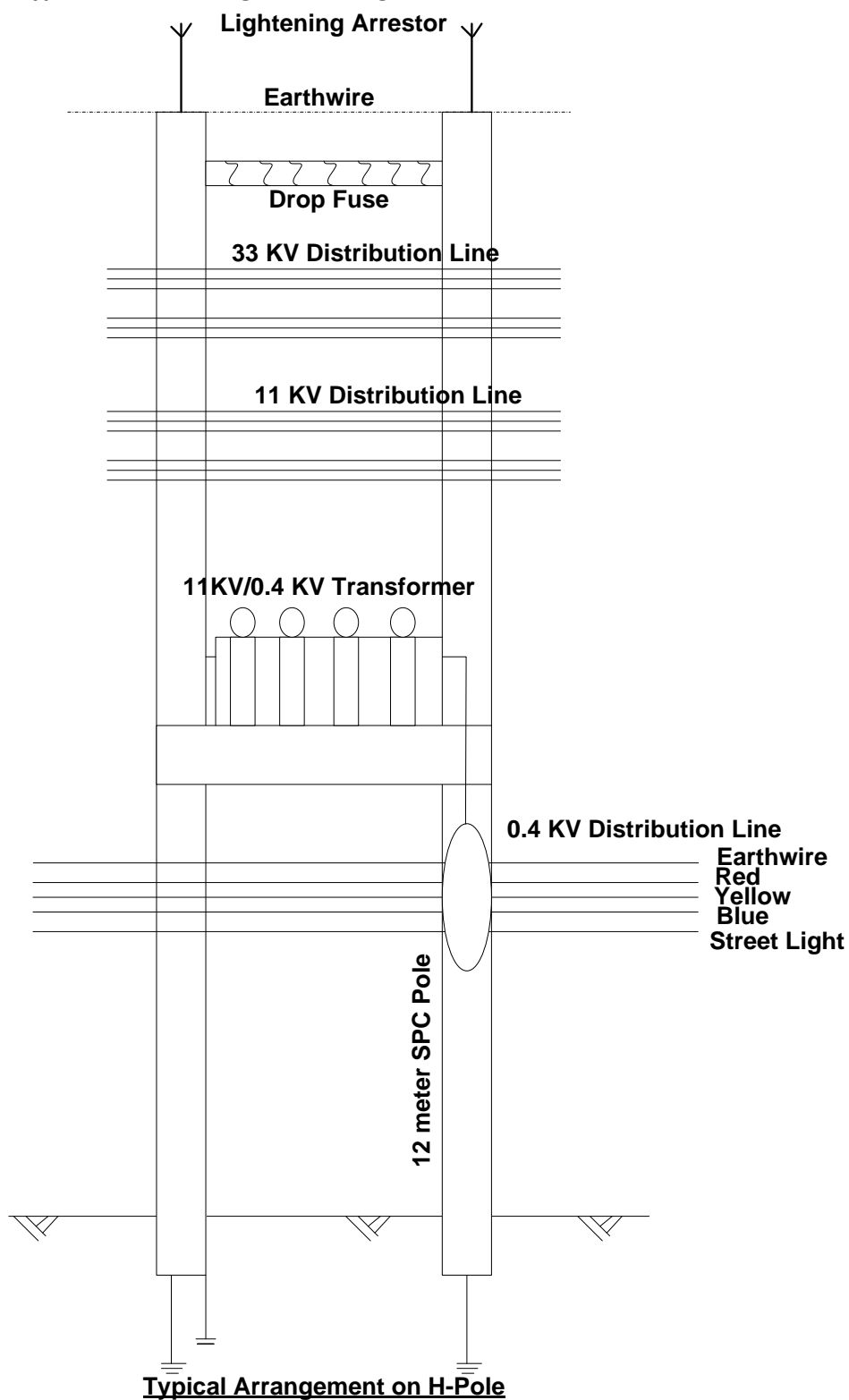

7.1.3. Household Connections and meters

Household connections are distributed from step down transformers (11KV/0.4KV) which are mounted on H-Poles (Figure 7.2) from which three phase lines (400V/ 220V) are extended to the domestic users. Figure 7.3 shows a Typical Transmission and Distribution System to the Household Level electrification diagram. Before entering the household, a meter box is installed to monitor the electrical supply. A switchboard with chain rover (switch) controls the electrical supply and cut off.

Figure 7.3: Electrical Power Transmission and Distribution System

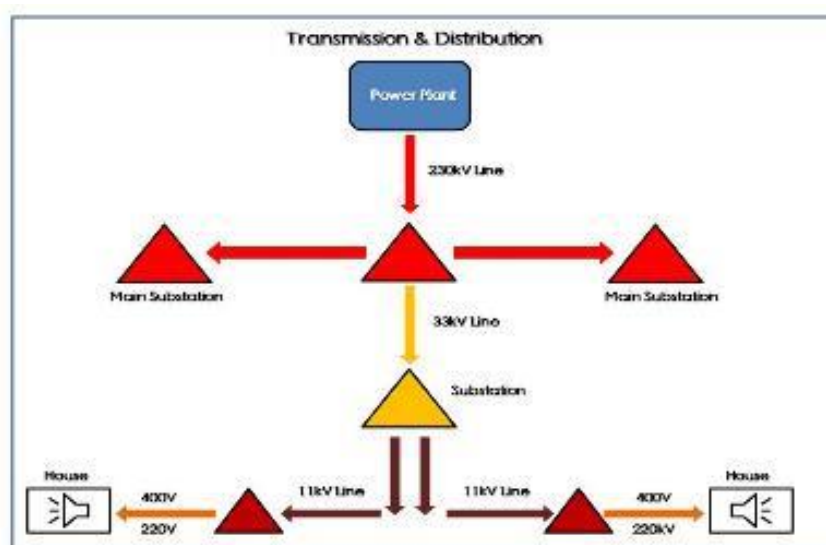

7.2. Off-Grid Electrification

The descriptions below are indicative. Actual design of each sub-project will vary according to local conditions, technologies used, and available materials.

7.3. Solar Home Systems

A large component of the off-grid electrification program is the installation of solar home systems (SHS). Solar energy is a renewable energy and is considered to be most suitable in regions where the sun shines brightly for at least several hours each day. However, even during the rainy season on most days sufficient solar energy can pass through the clouds and allow the systems to operate.

Solar Home Systems consist of a solar panel (0.02 – 0.05 KW) on a pole or on a house roof, battery, controller, inverter, and indoor wiring of bulb, lamps, cables and switches. Figure 7.4 below shows the components of a Typical Solar Home System.

For environmental purposes, care should be taken to use Lithium-ion batteries instead of the more prevalent but also more toxic Lead-acid batteries. If Lead-acid batteries are used, then safety measures such as safe disposal of used batteries should be systematically planned and considered for recycling. Furthermore, surveillance of the water content in the battery should be monitored to maintain its efficiency and safety against undesirable emission of air pollutants. The DRD PMO will set up a mechanism to take back old or non-functional lead acid batteries and centrally take care of adequate disposal to a reputable recycling firm. Under this scheme the return of those batteries will be incentivized to avoid sales to informal recyclers in Myanmar. It should be noted that a recent study of disposal of used batteries in Myanmar found the collection and recycling of Lithium-ion batteries to be quite underdeveloped, and so less likely to be disposed of or recycled effectively. The DRD PMO should set up a mechanism to take back old or non-functional Lithium-ion batteries, including a safe and sustainable means of disposal.¹⁰

The solar home systems should be provided equitably in the communities, to whoever wants and can afford to install a system. No minority ethnic or religious group should be left out, even if done so unintentionally. The SHS program includes installation of solar systems for public buildings (schools, health centers, religious buildings) and for street lighting. Care should be given that the systems are provided for all religious buildings, including those of minorities, and that the street lighting is well distributed in the community, including ethnic minority or poorer neighbourhoods.

Safety measures such as cutting trees branches or any obstacle that might prohibit the sunlight to enter the solar panel should be considered in choosing the installation site of the sub project. Care must be given to assure trees that are considered valuable to the households (such as fruit or other food trees) are not felled without permission from the household. Some households and most public systems may install the solar panel on the roof. Care must be taken to adhere to the relevant technical specification for installing the solar panel to get the maximum absorption of sunlight.

¹⁰ Manhart, Andreas; Ko Latt and Inga Hilbert, "Report on the Fact Finding Mission on the Management and Recycling of End-of-life Batteries used in Solar Home Systems in Myanmar," Oeko-Institut e.V., Freiburg, Germany, March 2018. Accessed online at <https://www.oeko.de/fileadmin/oekodoc/Batteries-from-SHS-Myanmar.pdf>

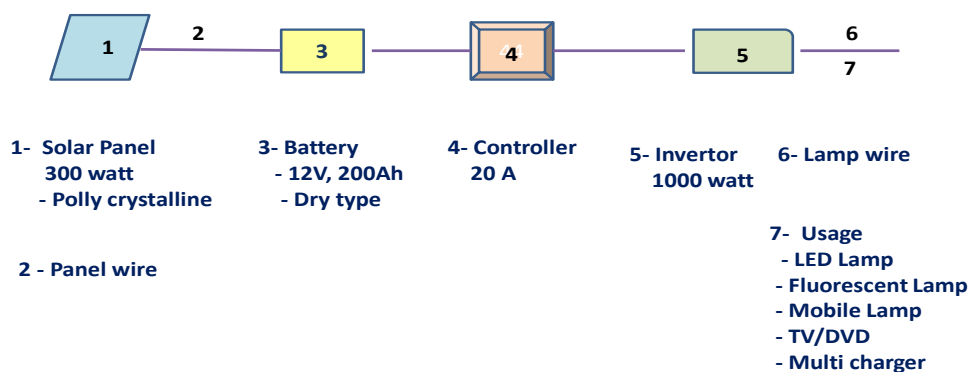
Figure 7.4: Components of a Typical Solar Home System

7.4. Results-Based Financing (RBF) Off-Grid Solar

The Results-Based Financing (RBF) Off-Grid Solar sub-project supports the IFC-led Lighting Myanmar effort that aims to develop commercial market solutions for quality-verified solar devices and kits in Central Myanmar. The RBF Off-Grid Solar sub-project will support sale of 95,000 Lighting Global certified systems by the private sector in Myanmar. It consists of two components: (1) results-based subsidies to eligible companies or local NGOs to sell Lighting Global certified products, and (2) implementation support.

The sub-project will increase market capacity and competition, which is expected to lead to availability of quality products at competitive prices. It will address high initial market development costs faced by the private sector in Myanmar, and so contribute to development of the supply chain and provision of improved quality sales and services.

The private companies and NGOs screened by the DRD PMO will offer Lighting Global certified products delivered with 1-3 warranty requirement, depending on product and after sales service. The Lighting Global testing procedure for small solar systems up to 10 watt peak (Wp) has become an international standard IEC-TS 62257-9-5, while the testing procedure for SHS kits up to 350 Wp is planned to be formalised as IEC standard in 2018. The participating companies and NGOs can either select from currently 134 certified products of 65 suppliers, or they can submit their untested products for certification. The Project will reimburse the companies/NGOs after certification of sales on a sample basis by an independent verification agent (IVA) hired by DRD.

Although operating essentially as businesses, the companies/NGOs supported by this sub-project should seek to be as inclusive as possible in marketing the solar lamps and systems, helping meet lighting and electricity needs of ethnic minorities, religious minorities, or other disadvantaged

groups in the communities. The companies/NGOs will be required to abide by an Environmental Code of Practice (ESCoP), similar to that for the SHS sub-project, which includes various environmental and social measures.

As noted above (in 7.2.1), the greatest environmental concern of solar home systems is the disposal of batteries. The DRD PMO is expected to set up a mechanism to take back old or non-functional lead-acid batteries and centrally take care of adequate disposal to a reputable recycling firm. The DRD PMO is also expected to set up a mechanism to take back old or non-functional Lithium-ion batteries, including a safe and sustainable means of disposal. The companies/NGOs participating in the RBF Off-Grid Solar sub-project will be expected to use these mechanisms.

7.5. Mini Grid Solar Photovoltaic (PV)

Under the Project, mini-grids can be built to generate and distribute electricity for villages from hydro, solar, biomass, wind, diesel or some combination of these. A Mini Grid Solar Photovoltaic (PV) usually consists of one or more solar panels (e.g. 50'x6'), cable, power station (charge controller, battery, inverter), AC Lines (3 phase, 4 wire) to users in a village (Figure 7.5). During the rainy season, when solar energy may not be sufficient, this system can be used together with a diesel engine or other source to provide continuous lighting to households.

In addition to the Safeguard measures for the SHS (Solar Home System) mentioned earlier, monitoring and surveillance for prevention of fire hazards, electrocution or any undesirable accidents should be considered during construction and operational stage of a solar powered subproject.

Figure 7.5 Components of a Typical Solar Mini-Grid System

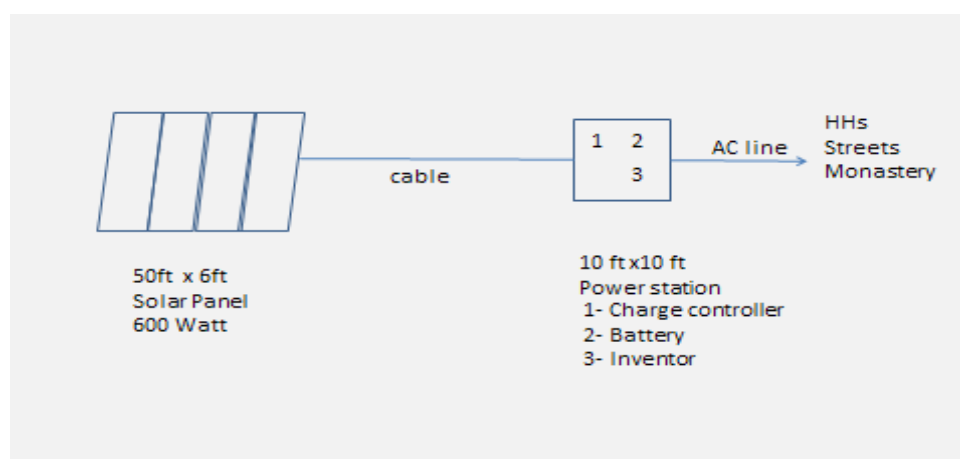

7.6. Bio Gas Power Plant

A Bio Gas Power Plant can consist of a small anaerobic masonry digester constructed below ground level. The system is used to convert animal wastes and plant wastes through anaerobic digestion

processes to produce energy that can be converted to electricity. A buried masonry anaerobic digester may generate gas to lamps. There may also be cook stoves and possibly a small engine.

A dual biogas power plant and system might consist of the following components: inlet tank (for example, cow dung mixed with water at a ratio of 1:1, grinder blades, sieve), bio digestion chamber, anaerobic digestion, gas storage in a dome shape with methane (CH₄ 60-70%), outlet tank, effluent slurry, gas pipe, water trap, hydrogen sulfide cleaner, 32 HP diesel engine and 30 kVA dynamo, mixer, panel board, 10g copper wire, with 7 meters high concrete posts. A flow-chart and cross section of such a power plant is presented in Figures 7.6 and 7.7.

Another biomass power plant might use plant residue such as rice husks only. Such a system would include the following components: rice husk storage cabinet, screw conveyor, gasifier, dry ash collector, cleaning and purifying devices, liquid and gas separator, cycle water tank, cycle pump, filters, root blower, and gas engine and generator. A flow chart of this type of rice husk biomass system is presented in Figure 7.8.

Safeguard measures such as installing manometer (pressure gauge) to check the pressure of the produced methane from the digestion chamber, water trap to take away the water content from the outlet gases, Sulphur cleaner and outlet pipe to control the hydrogen sulphide produced from the digester before entering the engine / dynamo to convert the bio gas into electrical power. Conventional safe handling practices should be adhered to and usage of safeguard measures such as PPE (Personal protection equipment) such as gloves, boots, masks, etc. should be provided to the worker(s) in operation. End product from the engine-gasifier such as grease / smoke should be disposed properly by installing grease / smoke trap for prevention before entering the soil or nearby water body.

Figure 7.6: Indicative Flowchart of a BioGas Plant

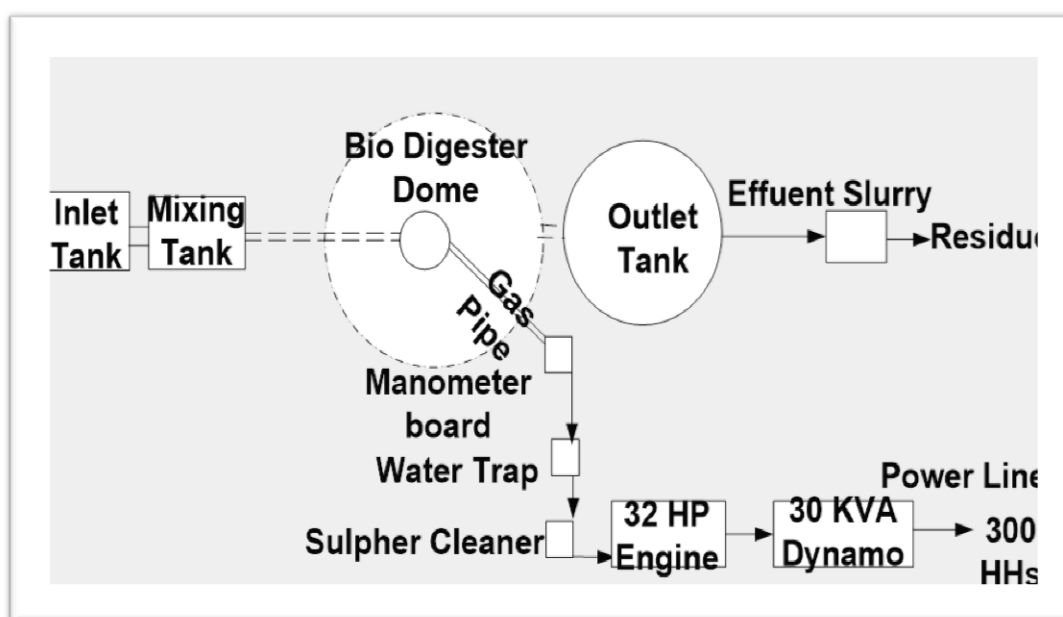

Figure 7.7: Indicative Cross-section of Bio Gas Plant

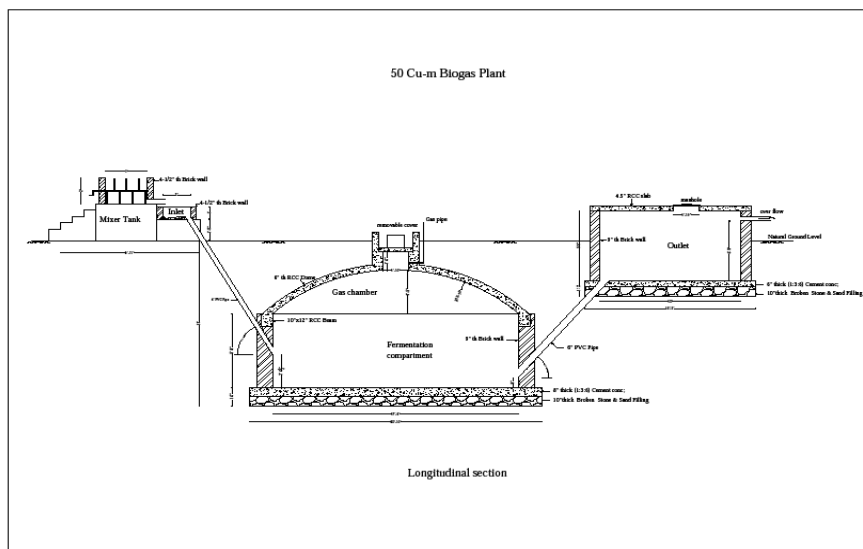
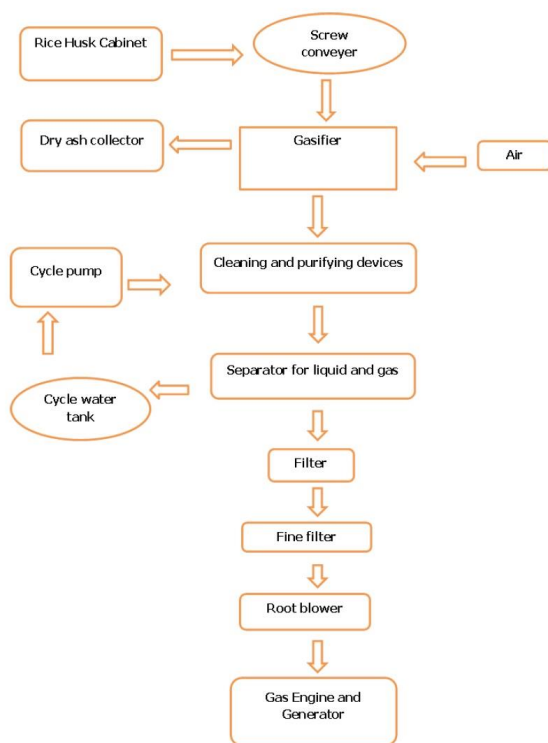

Figure 7.8: Indicative Flow chart of a Rice Husk Biomass Plant



7.7. Diesel Generator for Electrification

Diesel is a less preferred option under the Project due to its environmental and health impacts, however in some circumstances it may nevertheless be an appropriate solution, particularly as part of a hybrid system. It can provide a supplemental source of energy for solar mini-grids during the rainy season when solar energy is not sufficient, or for hydropower mini-grids during the dry season when water flow is inadequate.

The components of a typical diesel generator plant are an air fan, engine, battery, fuel tank, dynamo, exhaust pipe, concrete poles for cables, 3 phase, 4 wiring system to end users (Figure 7.9). A hybrid inverter will link the solar and diesel hybrid systems, while a synchronization panel will link the hydro and diesel hybrid systems, to assure automatic starts to the diesel system when either solar or hydro power production is insufficient.

Safeguards measures such as providing grease / oil traps or containers to capture potential oil spillage from the diesel engine to avoid polluting the soil or nearby water body are to be considered during installation. Growing trees in the compound of the sub project to absorb expected GHG (Green House Gas) emission and particulate matter from the exhaust of the engine. The exhaust pipe from the diesel engine should be checked for its height according to relevant technical specifications.

During operational stage, safety equipment (such as ear plugs) should be provided for workers to mitigate the impact of noise from the engine. If noise is found to exceed 80 dB (WHO Guidelines value), soundproofing should be seriously considered.

Figure 7.9 Layout Plan of a Diesel Generator Plant

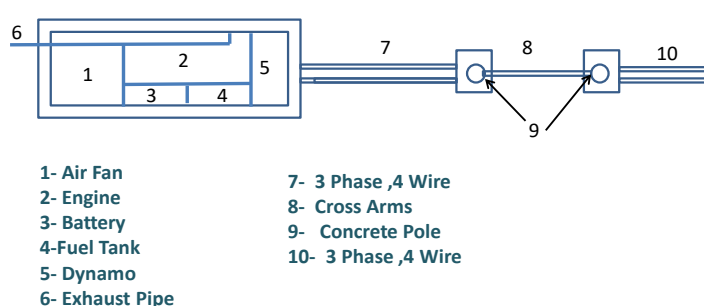

7.8. Mini Hydro Power Plant (<1MW)

Mini Hydro Power plants envisioned under the Project are run-of-the-river projects (which require little or no storage of water) and can be installed in place where the water drop and the steady flow

rate are high enough, although systems with small dams and storage reservoirs might also be considered.

A run-of-the-river hydropower mini-grid system requires one or more potential water sources. Figure 7.10 shows several of the components of a typical system, which can include: a head up weir (not shown) rerouting water to a power canal, a de-silting basin (not shown), a headrace to a forebay (if needed) (not shown) before entering the intake gate of a penstock, to the turbine and generator, with the water then flowing out through the tailrace and discharged back into the original natural stream. The electrical power generated from a mini hydro power plant is distributed through a low voltage network with a transformer and transmission lines, concrete poles for cables, a 3 phase 4 wiring system to the end user households.

Safeguard measures should include mesh or other structures at intake to prevent aquatic biota (fish, crabs, snails, etc.) from entering the power canal, and trash racks at the intake gate of the penstock designed to prevent any aquatic biota and other debris that may have entered the system from being sucked into the turbines. Structures should be included to prevent or reduce erosion of the natural stream banks and siltation into the intake, as well as prevent erosion from waters released through the tailrace. Measures to protect the banks with stone pitching and cement grouting should be considered. During operation, the debris from the trash racks should be separated into organic and inorganic matter, with the organic matter used for compost and the inorganic matter disposed according to arrangements set in a waste management plan.

Figure 7.10 Illustration of a Typical Mini Hydro Power Plant

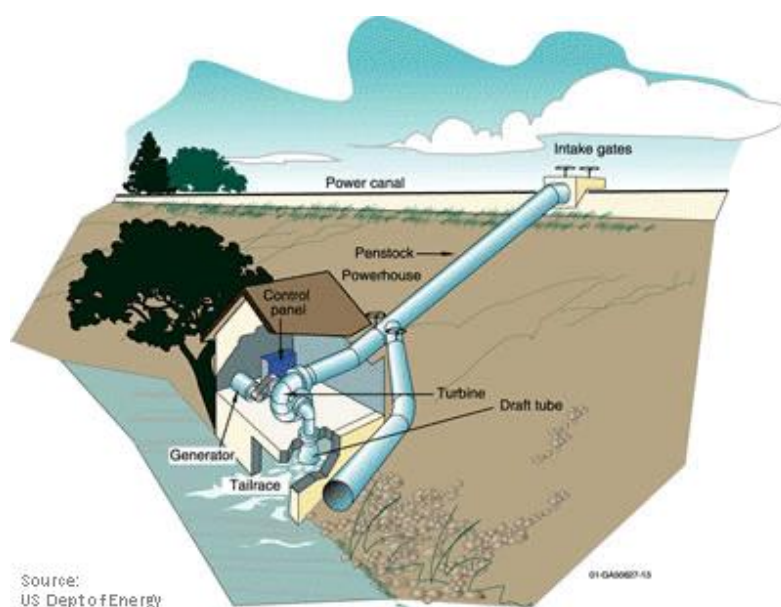

7.9. Wind Energy

Wind turbines range in size. The Project is expected to support only small wind turbines. Small wind turbines have direct drive generators, direct current output, aeroelastic blades, lifetime bearings and use a vane to point into the wind. Larger turbines generally have geared power trains, alternating current output, flaps and are actively pointed into the wind.

As a general rule, wind generators are practical where the average wind speed is 4.5 m/s or greater. Sites are usually pre-selected on the basis of a wind atlas, and validated with on-site wind measurements. Electricity generated with small turbines can be used to charge batteries or used directly.

Safeguard measures could reduce the potential for birds and bats being killed by the rotating blades. Site selection should avoid known migration pathways or areas where birds and bats are highly concentrated such as near wetlands. Turbines can be arrayed to reduce avian mortality (e.g. grouping turbines parallel to known bird movements)¹¹ and should be considered during design. Efficiency of Vertical Access Wind Turbines has improved greatly, and their use can greatly reduce avian mortality.

Sources of risk to workers during construction and operation, such as blade ejection, overheating of generators, tower collapse, hazardous weather conditions, handling heavy equipment, and fires caused by lightning strikes should be considered. Lightning protection, earthing measures, and good engineering design are among the possible safeguards measures.

8. Addressing Environmental and Social Impacts

8.1. ESMF Implementation Flowchart and Responsibilities for Grid Extension Component

8.1.1. For Activities Implemented by MOEE Utilities and Other MOEE Agencies

Screening and Scoping

The MOEE through its power utilities (ESE, MESC and YESC) will implement most of the grid extension activities, including all expansion of existing and construction of new medium voltage (MV) substations; construction of all new MV lines and 772 MVA of MV/LV transformers; much of the new low voltage (LV) lines, and some of the village networks and household and community connections (health clinics, schools and other public buildings).

For MV Substations and MV Lines: At the time of initial surveys for MV substation works or for the MV line construction, Township engineers of the MOEE utilities should complete the Grid Extension Screening Form (Annex 1), with assistance from the Union PMO safeguards team, to identify

¹¹ IFC, Environmental, Health and Safety for Wind Energy

potential environmental or social impacts in or near the area of the substations or along the MV lines.

Many of the environmental issues are dealt with in the ESCoP for MV Substations and MV lines and Transformers, and adherence to which should enable those implementing the projects to avoid or mitigate these impacts. The screening form helps alert the MOEE of the more evident environmental risks as well as the potential risks for people living near the grid extension activities.

Among the environmental issues covered by the screening forms are identification of difficult terrain where erosion or other problems may occur, and the presence of water bodies and waterways, wetlands, forests, and other natural habitats (including those for birds and bats) affected by the civil works. The social issues covered help identify nearby communities, people living along the right of way, land uses by nearby communities, houses or other structures that may need to be moved, and whether ethnic minorities are in any of the areas affected directly or indirectly by the project.

The screening forms are submitted to the MOEE PMO for review along with designs and other materials prepared for the activity. For every segment of the MV lines or construction or expansion of MV substations, the MOEE PMO determines:

- What are the potential environmental or social impacts, either direct or indirect?
- Based on the assessment of these impacts, what World Bank safeguards policies should be applied to the sub-project and any related activities?
- What additional documentation is needed to assure compliance with the safeguards, such as an Environmental and Social Management Plan (ESMP), and Indigenous Peoples' Plan (IPP), and Initial Environmental Examination (IEE)

The PMO will work with the appropriate MOEE utility staff to prepare the documentation as needed and to carry out consultations and negotiations with people affected by the activities.

For LV Lines and House Connections: Though most community LV networks and house connections will be done by the private contractors engaged by the VECs or by private investors, some of the community works may be done by the utilities. Before beginning any of the works, the utilities staff should complete the Community LV Network Screening Form (Annex 1). These screening forms will be submitted to the MOEE PMO along with preliminary designs for the network. The PMO will assess what additional documentation is needed, aside from the ESCoP for Community LV Networks and House Connections, and will work with the utility staff to prepare the documentation and to carry out consultations and negotiations as needed.

Training

The MOEE PMO Safeguards Team should provide training to MOEE utilities township engineers and to staff of any contractors involved in the grid extension activities. This training should be held on a regular basis (at least twice a year, or before planning for each round of civil works) to include all who are expected to be involved in the project in the coming months. The training should cover environmental and social requirements of the project, the Environmental and Social Code of

Practice, including the workers' code of conduct, and the grievance redress mechanism. Additional training should be provided for those involved in activities where an ESMP, RAP, and/or IPP is required, to enable them to work with the communities and carry out those plans effectively.

Monitoring and Evaluation

The MOEE Union PMO is responsible for monitoring these civil works, and will do so mainly through the MOEE utility township offices, to assure they adhere to the conditions of the ESCoP and any other safeguards plans. As the local representatives of the MOEE, the township engineers and district offices are responsible for following up on any grievances that have been brought to their attention.

The MOEE PMO Safeguards Team should make field visits to selected civil works to confirm compliance to the safeguards, adherence to the ESCoP, and adequate implementation of any other safeguards instruments. If the MOEE PMO has serious questions for any of the works about compliance to the safeguards or adherence to the ESCoP, or if grievances on environmental or social matters are brought to the attention of the MOEE PMO, a field visit and assessment to those particular works is required.

8.1.2. For LV Networks and Household Connections by VECs or Private Investors

Most of the community LV networks and household connections are done by the VECs who engage private contractors to carry out the works or by private investors. There is no screening for these activities as they are out of project and out of MOEE scope. Township engineers can provide technical assistance to the VECs and/or private investors upon request.

Monitoring and Evaluation

The MOEE township engineers carry out post installation verification to check the suitability and alignment of these networks with standard designs. As noted above, this is not part of the NEP, as these activities as they are out of project and out of MOEE scope.

8.2. ESMF Implementation Flowchart and Responsibilities for the Off-Grid Component

8.2.1. For Solar Home Systems and RBF Off-Grid Solar Components

Screening and Scoping

The activities of the Solar Home System (SHS) and RBF Off-Grid Solar components have in general quite low risk of environmental or social impacts. Screening by DRD of qualified contractors making bids or of the companies and NGOs selected to participate in the RBF Off-Grid Solar programme, training key staff of the contractors and the companies/NGOs in environmental and social requirements, brief en bloc screening at the Township level prior to installation, and adherence to

the Environmental and Social Codes of Practice (ESCoP) for the SHS and the RBF Off-Grid Solar sub-projects should enable the contractors and companies/NGOs to avoid or mitigate these impacts.

Screening for Inclusion

For SHS: The DRD Township PMO determines the communities to be covered by the SHS and solicits participation by the households in those communities prior to the call for bids. As part of this process, the Township PMO should complete a screening form on basic environmental and social issues, including presence of ethnic, religious, or other minority groups (SHS Township Screening Form, Annex 2).

For RBF Off-Grid Solar: The companies/NGOs will complete a screening form for each community where the solar home kits are sold (RBF Off-Grid Solar Screening Form, Annex 2). This form includes questions about ethnic, religious, or other minority or disadvantaged groups in the community, as well as environmental aspects.

The NEP PMO Safeguards Team reviews the Township and Off-Grid Solar screening forms to determine if there are any issues relating to the World Bank safeguards policies that need to be addressed prior to or during installation.

Training

For SHS: The NEP PMO Safeguards Team and Communications Team should provide training to the contractors (in particular to the supervisors of installation) on environmental and social requirements of the project, the Environmental and Social Code of Practice, including the workers' code of conduct, and the grievance redress mechanism. This training should be after the contractors have been selected, but before they begin installing the SHS.

For RBF Off-Grid Solar: The NEP PMO Safeguards Team and Communications Team should provide training to the companies and NGOs on environmental and social requirements of the project, the Environmental and Social Code of Practice, including the workers' code of conduct, and the grievance redress mechanism. This training should be after the companies and NGOs have been selected to participate, but before they begin sub-project activities.

Monitoring and Evaluation

For SHS: The contractor completes several forms after installation, including one on the households not receiving SHS (Form NEP-4: Households not participating in the SHS Programme). The form includes information whether the household is an ethnic or religious minority in the community or a vulnerable household, and the reasons why the SHS was not installed.

For both SHS and RBF Off-Grid Solar: Inspection and verification of installation is done by Inspection and Verification Agents (IVA) and recorded in the project's MIS. Surveys conducted by the IVAs include questions on ethnicity and gender issues, and on adherence to the ESCoP.

These documents are reviewed by the NEP PMO Safeguards Team to evaluate if the SHS program is complying with the environmental and social safeguards.

8.2.2. For Mini-Grid Systems

Screening and Scoping

For every mini-grid sub-project, the DRD PMO determines the following:

- What are the potential environmental or social impacts, either direct or indirect?
- Based on the assessment of these impacts, what World Bank safeguards policies should be applied to the sub-project and any related activities?
- What additional documentation is needed to assure compliance with the safeguards, such as an Environmental and Social Management Plan (ESMP), and Indigenous Peoples' Plan (IPP), and Initial Environmental Examination (IEE)

The project proposal process for NEP mini-grids consists of two stages, referred to as “pre-feasibility study” and “feasibility study”. The pre-feasibility study consists of initial descriptions of the proposed sub-project, including descriptions of the communities, energy demand and proposed sources of energy, engineering design, management and organisation, environmental and social aspects including compliance measures, project implementation plan, and financial analysis. The “feasibility study” provides more detailed assessment of each of these categories, including additional information and documentation requested by the DRD PMO and the World Bank. Priority is given to sites pre-selected by the DRD for development of mini-grids, though developers can also propose sites they have identified.

Pre-feasibility study

The developer is required to complete an initial screening form, to indicate the possible environmental and social impacts of the sub-project. A separate screening form is available for each type of technology being proposed thus far – solar, biomass, mini-hydro, and solar-diesel, wind-diesel, and biomass-diesel hybrids (Annex 3). Although many of the questions are the same in all the mini-grids, some questions and sections are tailored to the particular technologies, given different expected environmental impacts. The screening form is to be completed with the assistance of VEC members or other village leaders, who are to be identified on the screening form. The screening form is then submitted to the DRD Township Officer, who reviews and confirms the information by signing and dating the form. The developer can request assistance from the DRD Township PMO for this initial visit, particularly if it is a DRD selected site with which the developer is not yet familiar.

Based on the information in the screening form, the developer describes the potentially adverse environmental and social impacts and the proposed mitigation measures to avoid or reduce those impacts, including a list of all additional documentation required at the feasibility study stage. An indicative outline for this section of the pre-feasibility study is provided in Annex 6.

The pre-feasibility study also includes other documents relevant to safeguards, notably the VEC Application for Mini-Grid Screening and the Memorandum of Understanding between the Developer and the VEC, both of which indicate interest on the part of the community for the mini-grid sub-project.

The NEP PMO mini-grid unit receives the pre-feasibility studies, with the Safeguards Team responsible for reviewing the screening form, the sections of the proposal dealing with safeguards and compliance, and other relevant documentation. The Safeguards Team provides comments and recommendations for any additional assessment or documentation needed in the “feasibility study” stage of the proposal. This would include whether or not the sub-project requires an IEE. The Annex 1 of the Environmental Impact Assessment Procedures under the Myanmar Environmental Conservation Law automatically requires an IEE for hydro-power projects of ≥ 1 MW but < 15 MW and with a reservoir area covering < 400 ha. Other technologies under the NEP off-grid component automatically require IEE only if ≥ 5 MW, which is not expected. Even if not automatically required, the NEP PMO may require an IEE if any significant environmental and/or social impacts are possible.

Other information or documentation that the Safeguards Team may require for the feasibility study stage could include, but not be limited to, an ESMP, IPP, Resettlement Action Plan (RAP) for compensation of land or loss of livelihoods, Waste Management Plan (if not already included in an ESMP), evidence of public consultation with the communities (including neighbouring or downstream communities if affected by the project), photographic evidence (of consultations, environmental conditions), proof that information provided to and consultation with the local community is in the language they understand (including that of any minority ethnic group within the community) recordings (audio or video) of further consultation meetings, environmental measurements, and assessments of the impacts of the project on women, ethnic and/or religious minorities, or the poor and other disadvantaged groups in the community.

Feasibility study

After the NEP PMO approves the pre-feasibility study, the developer prepares a feasibility study, which includes all the additional information and documentation indicated by the developer as well as the additional information and documentation requested by the NEP PMO. If an ESMP and/or IPP and/or RAP are required, the developer should prepare according to the guidelines provided in Annexes 2, 6 & 7 and 8 & 10 of this report).

The developer carries out further consultations with the community and any other affected people and/or stakeholders during this stage, presenting the proposed project, the expected environmental and social impacts and mitigation measures. Sufficient evidence of these consultations should be included in the feasibility study, including photographs, written minutes of meetings, lists of participants with their signatures or markings, and if possible audio or video recordings. A representative of the Township PMO should attend community level consultations as a witness and to provide additional information about the project, its objectives, safeguards, etc., if requested.

If it has been determined that the World Bank Safeguard on Indigenous Peoples (OP 4.10) is triggered, the developer must show (1) that the ethnic minorities were engaged in free, prior, and informed consultation during project preparation in their language and with means of communication appropriate to their culture, (2) that their views have been adequately ascertained and incorporated in the design, and (3) that there is broad community support for the sub-project, by both men and women.

The NEP PMO reviews the draft feasibility study after submission by the developer, with the Safeguards Team responsible for review of all the environmental and social aspects, assuring the documentation is sufficient and the compliance mechanisms are adequate to mitigate any of the expected impacts.

The feasibility study can be sent back to the developer for revision if any aspects are not adequately addressed. This can be done any number of times until the NEP PMO is satisfied. Once approved, the final proposal document is sent to the World Bank for review and comments and possible further revisions.

Once final approval is given to the sub-project, a tripartite agreement is signed between the NEP DRD, the developer, and the VEC of the community or communities to be served by the mini-grid. The contract with the developer will include all the implementation plans (ESMP, IPP, RAP, etc., as required) and the Environmental Code of Practice and the Workers' Code of Conduct.

Training

The NEP PMO Safeguards Team and Communications Team should provide training to the developers (in particular to construction supervisors) on environmental and social requirements of the project, the Environmental and Social Code of Practice (ESCoP), including the workers' code of conduct, and the grievance redress mechanism.

Monitoring and Evaluation

Overall responsibility for monitoring and evaluation is with the DRD PMO, who will work through the Township DRD office to monitor construction of the sub-projects and assure they adhere to the conditions of the contract and tripartite agreement. As the local representative of the DRD, the Township PMO is responsible for following up on any grievances that have been brought to its attention.

The developer prepares monthly reports, which include reports of compliance to the environmental and social safeguards, and adherence to the ESCoP and any environmental or social plans, including progress in any actions required.

The NEP PMO Safeguards Team reviews the reports from the developer and provides comments and requests additional information as needed. The Safeguards Team should join the Mini-Grid Unit on field visits to sub-projects to confirm compliance to the safeguards, adherence to the ESCoP, and adequate implementation of any other safeguards instruments. If the NEP PMO has serious

questions about compliance to the safeguards or adherence to the ESCoP, or if grievances on environmental or social matters are brought to the attention of the NEP PMO, a field visit and assessment to the sub-project is required.

Consultants

Consultants can be engaged by the developer to conduct the IEE and prepare other safeguards documents, on condition that the consultant abides by all World Bank safeguards policies. The developer is responsible for all actions of the consultant in the field, including all interactions with the local communities and residents. The developer remains responsible for all the documents prepared and information provided by the consultants, and must show sufficient knowledge of all aspects of the work conducted by and materials prepared by the consultants.

The PMOs may contract consultants to support monitoring of compliance with environmental and social safeguards by a sub-projects or group of sub-projects. The responsible PMO prepares a TOR and procures the contractor for safeguards implementation supervision/monitoring in accordance with World Bank procurement rules.

The PMO includes reporting on safeguard implementation as a chapter of its normal project status reports and regular monitoring reports.

World Bank environmental and social specialists will supervise compliance and inform the World Bank's Regional Safeguard advisor.

Application of World Bank Safeguards and ESMF to Other Financiers

The World Bank Environmental and Social Safeguards and this Environmental and Social Management Framework apply to all components or sub-projects of the NEP Project, even if that component or sub-projects are funded entirely by another Development Partner or private party.

8.3. Guidelines for environmental and social screening of sub-projects

Potential impacts of each component or sub-project have been divided into:

- (A) impacts during construction, and
- (B) impacts during operations.

For each phase, the impacts have been further categorized into: ecological, physical-chemical impacts, and social impacts. A number of parameters have been identified for each of these categories: extent, duration, magnitude/intensity, probability and significance. During the screening process, the significance of each impact will be classified as "significant", "moderate" or "low". This classification will inform the level of detail of the further environmental and social analysis required.

8.3.1. Ecological Impacts

Generally, four parameters have been considered for screening of ecological impacts during construction phase:

1. presence of Natural Habitats land and water areas where the biological communities are formed largely by native plant and animal species and human activity has not essentially modified the area's primary ecological functions) for which protection is required under WB Safeguard policies (including Natural Habitats) and Myanmar Laws,
2. felling of trees,
3. clearing of vegetation, and
4. impact on terrestrial / aquatic / avian habitat.

If the subproject or related infrastructure affects a Natural Habitat, then alternative design should be made if possible for those elements of the sub-project to avoid risk to biodiversity, vegetation and natural habitats. However, it may not be possible in all cases to avoid these areas, even with alternative design. The proposed route, for example, of a power line subproject may need to pass through biodiversity areas and a notable biological corridor. It would be necessary to identify possible route(s) that would reduce the risk to biodiversity, vegetation and natural habitats. In such a case, when it is not possible to completely avoid such sensitive areas, and the responsible PMO deems it necessary to implement this sub-project, then the possible impacts on biodiversity must be further analysed with an IEE or an ESIA appropriate to the expected impacts and mitigation measures proposed.

Hydropower projects will necessarily have an impact on the aquatic ecology, and other sub-projects may also affect waterways with pollution, sewage and waste disposal, and other potential impacts. Wind turbines can affect birds and bats, with potential impacts to migratory patterns, preferred habitats, and feeding patterns, as well as death from collision with the blades of the turbine. The electromagnetic field (EMF) of MV electrical power lines should also be screened for the potential impact on communities and biodiversity, mostly avian. The potential for these various environmental impacts can each be assessed as significant, moderate or insignificant.

For the impact on natural habitats located close to the proposed sub-project, the potential adverse impacts during construction and operation, such as discharge of waste/wastewater, spills and leaks of oil and other chemicals, should each be assessed as significant, moderate or insignificant depending on proximity of the proposed sub-project to the habitat and the severity of its impact if there are no mitigation measures.

For felling of trees and clearing of vegetation, the impact of each could be classified as significant, moderate or insignificant depending on the number of trees or the amount of biomass removed and its importance for ecosystems nearby, as well as its impact on hydrology and erosion.

If any of these impacts are considered significant, the responsible PMO can request preparation of either an IEE or ESIA, depending on the potential severity of the impacts.

8.3.2. Physical-Chemical Impacts

The parameters considered for screening of physical-chemical impacts during construction phase of a subproject include

- noise and air pollution
- water pollution or land pollution
- changes in water flow or drainage congestion

If construction of the sub-project involves use of equipment/machines producing significant noise (e.g., generators, pile drivers) and if the proposed subproject site is located close to human settlements/schools/hospitals, then noise pollution would be significant (in the absence of mitigation measures). Similarly, use of stone crushers, excavation works and vehicle movements generate dust and air pollution. Possible air pollution from activities involved in subproject construction is not likely to be significant, and could be classified as "minor", unless the subproject site is located very close to human settlements.

If there is a water body (pond/stream) located close to the proposed sub-project location, then the potential adverse impact (e.g., through discharge of waste/wastewater from subproject activities, spills and leaks of oil /chemical) on water quality could be classified as "significant" or "moderate" or "insignificant", depending on the of the proposed subproject location to the water body and the nature of the water body (i.e., whether it is an important habitat for aquatic flora / fauna).

If the location of proposed sub-project infrastructure, such as a sub-station site, obstructs the flow of natural drainage water, then it could generate "significant" drainage congestion/water logging during both construction and operational phases of the substation; otherwise impacts on drainage would most likely be "minor". Hydropower sub-projects will affect the flow of the water sources. The affect of the project on water flow can be classified as "significant" or "moderate" or "insignificant", depending on the extent and duration of disruption. For example, impact may be considered "significant" if the minimum environmental flow is not maintained for more than several days.

During the operation of a subproject, physical or chemical environmental parameters would include, but not be limited to noise level, air pollution, erosion and siltation, drainage congestion, water logging, water pollution, solid/liquid waste disposal, and likelihood of hazardous materials. These should all be screened for their potential impact as significant, moderate or insignificant depending on the likely severity without mitigation measures.

If any of these impacts are considered significant, the responsible PMO can request the developer to prepare either an IEE or ESIA, depending on the potential severity of the impacts.

8.3.3. Social Impacts

The proposed sub-projects are expected to result in a number of positive social impacts. This could include improvements in livelihoods and economic development, improved health and education services and community safety, as well as improvement in women's lives. Some positive impacts will be the direct result of project activities, while others could result from initiatives undertaken by development partners and businesses, as well as by the local residents themselves, following the improved access to electricity.

Even so, some sub-projects could pose social risks to and have adverse social impacts on local communities and households. Such adverse impacts and risks could include:

- Permanent loss of land and assets on the land such as trees and standing crops needed for the infrastructure, or temporary loss of land for construction sites, or loss of livelihoods because of limited use imposed on some lands or other resources;
- Social exclusion, for the individual households that cannot afford access to the electricity services or for neighbourhoods or nearby communities that do not yet have access;
- Indebtedness, due to the cost of electricity and purchase of new electrical appliances and devices;
- Negative impacts to ethnic minorities and other vulnerable groups, in particular due to potential exclusion from project benefits such as access to electricity and improvements in health and education services;
- Variable governance and capacity within Village Electrification Committees (VECs), which can affect the quality of implementation of sub-projects and the level of benefits achieved.

For most sub-projects, the primary potential adverse social impacts concern loss of land and livelihoods, and social exclusion of poor and other vulnerable households and groups. As much of the grid extension and most of the off-grid projects are in more remote regions of the country where most of the ethnic minorities reside, there is also the potential for adverse impacts on those ethnic minorities, as well as on other vulnerable groups such as religious minorities.

Land and Livelihoods: The potential impacts of sub-projects to land and livelihoods could include direct or indirect changes of land use; loss of income through temporary or permanent change in land or other resource use; and the need for land acquisition. The footprint of sub-projects is generally small and it is not expected that people would need to relocate or resettle, although the Resettlement Policy Framework (RPF) allows for this should it be needed in exceptional cases.¹² Sub-projects may also include instances of voluntary land donation where infrastructure will be built. While OP 4.12 on Involuntary Resettlement does not directly cover such donations, they are closely related and should only occur under strict conditions. There must be alternative sites available for that infrastructure, so the land owner/user can decline a request to donate the land and the sub-

¹² OP 4.12 covers direct economic and social impacts that result from Bank-assisted investment projects, and are caused by the involuntary taking of land resulting in (i) relocation or loss of shelter; (ii) loss of assets or access to assets; or (iii) loss of income sources or means of livelihood, whether or not the affected persons must move to another location.

project can use the alternative site. If no alternative site is available, the land owner/user must receive compensation at market price. If land is donated, it cannot account for more than 20 percent of the land owner/user's total productive land holdings. A protocol for voluntary land donation is presented at Annex 9.

It is important to assess early the potential impacts of proposed subprojects on livelihoods within the proximity of the proposed subprojects, both those livelihoods linked to use of land and also other livelihoods that may be affected by the proposed subproject. The RPF provides the protocol for compensation for permanent and temporary loss of livelihoods and loss of assets, in addition to the permanent and temporary loss of lands and assets.

Ethnic Minorities and Vulnerable Groups: There is the potential that ethnic minorities and other vulnerable groups may not be able to receive equitable benefits from NEP subprojects. They may be excluded from local decision-making processes that discuss strategies and approaches to access electricity. Contractors or developers working in their communities may not be aware of or respect their local customs and culture.

Under the NEP, screening for the presence of ethnic minorities will be undertaken to determine the need for free, prior and informed consultation with these communities, and to determine whether the developer should prepare a sub-project Indigenous Peoples Plans (IPP), as required by OP 4.10. (see the Indigenous Peoples Planning Framework, Annex 9) Consultation and social assessment—at a scale proportional to the sub-project's potential impacts—may be required to gain insights into potential cultural, language and other dimensions that need to be considered in order to ensure that sub-projects provide appropriate benefits to, and do not have adverse impacts on, ethnic minorities.

Whether and IPP is deemed necessary or not, communication and consultations with local communities should be in the language they understand. If there is more than one ethnic group in a community using more than one language, communications and consultation should be made in all the languages used in that community, so that no persons or groups are intentionally left out of the process. If the contractor for SHS or the developer of a sub-project does not have in-house capacity in any of these languages, they will need to engage translators or staff who can communicate with those ethnic minorities.

The screening process can also be used to identify other vulnerable groups and individuals that could be affected by subprojects, including potential exclusion from involvement in subproject activities. Such vulnerable groups could include religious minorities, refugees and displaced communities, while vulnerable individuals could include widows, single mothers, orphans, the elderly, disabled persons, and women more generally.

8.3.4. Physical Cultural Resources

Subprojects are also screened to ascertain their likely impacts on physical cultural resources. Guidelines for identification of physical cultural resources are presented in Annex 7. Procedures in case of a “chance find” (that is, the discovery of an object or site of archaeological, historical, or cultural importance to the nation, region, or local community) are presented in Annex 8.

8.3.5. Local Benefits

The screening process should also be used to identify and optimise the potential local benefits that each subproject could contribute within the communities where it will be implemented. Such benefits could include creation of opportunities to employ local businesses and workers in subproject construction, and in operations and maintenance, and also to provide training and skills for these opportunities.

The Project also intends to provide electricity to social infrastructure within communities - such as health clinics and schools - and to provide streetlights to enhance community safety, particularly for women and children. The screening process will be used to identify the best locations for the public electricity infrastructure, as agreed through consultations with the community. Provision of the social infrastructure must include facilities used by ethnic or religious minorities or other vulnerable groups, and the streetlights should be well distributed throughout the community to cover neighbourhoods of ethnic minorities or poor or other vulnerable groups.

8.4. Optional Approach to Score Environmental and Social Impacts

In general, the screening process will identify the nature of potential impacts (positive and negative) that the subproject could generate within its area of influence (see section 8.5. below). This will inform the selection of the safeguards instrument that would be required to assess the potential impacts in further detail. The choice of safeguards instrument primarily depends on the degree of significance of anticipated environmental and social impacts and the level of associated environmental and social risks.

During the scoping stage, the PMOs will confirm the key environmental and social issues, risks and potential impacts that were identified during the screening process. The scoping stage can highlight potential issues at the early phase of sub-project development thereby allowing design changes to be made to mitigate potential environmental and social impacts and the project location to be modified.

If helpful for certain subprojects, the PMOs can use an Impact Assessment Matrix to identify the likely significance of each identified potential environmental and social impact. Scores are provided for each potential impact by considering four variables: the physical *Extent* of the impact, the expected *Duration* of that impact, the *Probability* the impact will occur, and finally the *Magnitude* of the potential impact. Each variable is assigned a score of 1 to 3 based on the criteria in Table 8.1. A list of potential environmental impacts for all the types of NEP subprojects is presented in Annex 4, and a list of potential social impacts is presented in Annex 5.

Table 8.1. Scoring for Extent, Duration, Probability and Magnitude

SCORE	Extent	Duration	Probability	Magnitude
1	Direct impact zone: Within the works/site area or immediate surroundings	Short: The impact is short term (0- 12 months) or intermittent	Low	Low: No or negligible alterations to environmental functions and processes
2	Locally: Effects measurable/noticeable outside the works area and immediate surroundings	Medium: Medium term (1-2 years)	Medium	Medium: Natural ecosystems are modified
3	Wide Area: The activity has impact on a larger scale such as sub-catchment or entire city	Long: the impact persists beyond the construction phase for years or the operational life of the project and may be continuous	High	High: Environmental functions altered

The significance of the impact is then deemed as low, medium, or high by using this formula:

$$\text{Significance} = (\text{Extent} + \text{Duration} + \text{Probability}) \times \text{Magnitude}$$

A potential impact is rated as low-risk when the total is less than 9, as medium-risk when the total is between 10 and 14, and as high-risk when the total is 15 or above.

Although most of the impacts being measured will be negative, some potential impacts could also be positive. Those using the Impact Assessment Matrix should first determine if any of the impacts are expected to be positive, and calculate accordingly.

If most of the potential impacts are shown to be low risk, the only safeguard instruments required could be the ESCoP with adequate monitoring and post-construction assessment. However if some of the impacts are rated as moderate to high, an ESMP may be required, depending on the type and severity of the impacts. If there is involuntary loss of land, assets or livelihoods, a RAP is required, and if the sub-project is in a community or area with ethnic minorities, an IPP is required. If some impacts are rated as high, with potential for serious environmental or social harm, an IEE may be required in addition to an ESMP, RAP and/or IPP.

8.5. Sub-project Area of Influence

It is critical that the sub-project area of influence includes all people or areas that are potentially affected by the sub-project. The area of influence can be defined as the geographic area where the environmental and social impacts of a sub-project would or could be experienced. This consists of the sub-project's direct area of influence and the area of influence of its activities. In order to establish a sub-project area of influence, the activities to be carried out and processes that would take place during both the construction and operations phases of a sub-project need to be carefully evaluated.

When defining a sub-project's area of influence, it is important to consider both the type of sub-project (SHS, mini hydro, biomass, etc.) and the area where it will be implemented (e.g. near a water body, a school, a house, productive land, etc.). For the majority of the sub-projects, the area of influence is likely to be limited to the footprint of the works (land plots, corridors of power lines, access roads, etc.) and its direct vicinity. Some impacts however, such as noise and air pollution, can have effects beyond the footprint of the works. Attention is required also for impacts on waterways because hydropower mini-grids can have downstream effects and cumulative impacts to other water uses. Disposal sites for waste and hazardous materials also need to be considered as part of the sub-project's area of influence, even if at a distant location.

In defining the area of influence, it is also important to carefully consider land ownership and use. In some cases, land can be communally owned and/or used by groups that may not live in immediate proximity to the sub-project site. Such groups may also be required to be included within the sub-project's area of influence.

Similarly, if items of physical cultural resources or cultural heritage are included within the geographic area where the environmental and social impacts of a sub-project would or could be experienced, they would need to be considered in defining the sub-project area of influence.

Table 8.2 below provides general guidelines to identify the sub-project area of influence when limited to the footprint of the works and direct vicinity. As mentioned above, depending on the sub-project, the area within which it will be implemented and the significance of the identified potential

impacts, the area of influence may include a sub-catchment for mini-hydro impacts on sediment flow/ecosystems or an air basin for diesel impacts on air quality.

Table 8.2 Guidelines for identifying direct area of influence when limited to the works¹³ footprint

Subproject	Area of Influence
Substation	<p>Areas and communities surrounding the location of the Substation who may be affected by construction activities.</p> <p>Areas on either side within ~15 m (49 ft) of the access road from the main road to the Substation</p>
Power Line	<p>Right of Way for the Distribution line:</p> <p>For 33 kV Distribution Power Line - 12 ft (3.6 m)</p> <p>≤ 11 kV Distribution - 8 ft (2.4m)</p> <p>No building or human habitation within the ROW of the Distribution Power Lines</p>
Household meters and connections	No defined particular distance
Bio Gas Plant	Surrounding area within 50 ft (15m) of sub-project effluent slurry (no tube to be drilled to prevent pathogen / ecoli infection)
SHS (Solar Home System)	Areas and communities 0.2 km (0.12 mile) around a solar home system using Acid Type Battery
Mini Grid Solar Photovoltaic (PV)	Areas and communities 0.5 km (0.31 mile) around a mini grid solar photovoltaic (PV) system
Mini-Hydro	Area 0.5 km (0.31 mile) within forebay water shed area and 2 km downstream of Mini Hydro Power Plant
Diesel Engine for Electricity	Within 7m (23 ft) of the surrounding area from a diesel engine (<500 kVA)

¹³Information provided by Union PMOs (MOEP/MLFRD) during site visit in February 2015 and confirmed with ESE and DRD Officers in Nay Pyi Taw on 28 April 2015

Wind System	Energy	Atmospheric area of flying birds and insects within 1 km (0.62 mile) of Wind Energy Plant
-------------	--------	---

Ancillary Facilities

Although the Project will finance specific sections of grid and off grid electrification, some ancillary facilities (such as HV transmission lines; access roads; water supply lines) could be essential for the NEP to achieve its development objectives. Therefore, and as part of the World Bank OP 4.01 requirement for environmental and social impact assessment to include “the area likely to be affected by the Project, including all its ancillary aspects”, the Project will carry out reasonable due diligence in relation to existing or simultaneously built ancillary facilities that will be connected to and/or that can be affected by the Project. As part of this due diligence it is expected that the PMOs will:

- Determine the type and location of ancillary facilities (e.g. power plants and HV transmission lines) that will be feeding and or are a fundamental part of the grid roll out or rural pre/electrification schemes.
- Carry out an audit to assess the environmental and social performance of the ancillary facilities, and develop an action plan if non-compliance with the World Bank Group Operational Policies identified as pertinent to the Project is identified.

8.6. Selection of Safeguards Instruments

8.6.1. Environmental and Social Code of Practice (ESCoP)

Every type of sub-project has an Environmental Code of Practice (ESCoP), which describes the types of measures to be taken to prevent or minimise environmental or social harm. For many of the sub-projects, the ESCoP will be considered sufficient, as the environmental and social impacts are expected to have very low impact, over a limited area, and low risk of occurring. The ESCoPs provide the guidelines to assure those potential impacts are avoided.

For the grid extension component, the ESCoPs for MV works and for LV works and connections are automatically included as a part of any work order for the utility companies and of any work by VECs including work carried out by private investors or companies for VECs (Annex 15).

For the off-grid component, the ESCoP for SHS is included as part of the contracts with the companies that win the block bids, and the ESCoP for the RBF Off-Grid Solar sub-project is provided to any supplier selected by the DRD PMO to participate (Annex 16). The ESCoPs for the mini-grid sub-projects are designed for each type of technology being used, with the appropriate ESCoP included in each contract (Annex 17). Every ESCoP includes a Workers’ Code of Conduct, providing rules of behaviour for workers and other staff when implementing the sub-projects.

8.6.2. Environmental and Social Management Plan (ESMP)

An Environmental and Social Management Plan (ESMP) will be prepared for those sub-projects where there are more than a few potential environmental and/or social risks, even if the impacts are classified as low or medium. The primary objective of the ESMP is to record environmental and social impacts resulting from the sub-project activities and ensure implementation of the identified mitigation measures. An ESMP is prepared in order to reduce adverse impacts and enhance positive impacts. It is also intended to address any unexpected or unforeseen environmental and social impacts that may arise during the construction and operations phases of the sub-projects.

The ESMP should clearly lay out:

- (a) the measures to be taken during both the construction and operations phases of a sub-project in order to maximise potential positive environmental and social impacts and eliminate or offset adverse impacts, or reduce them to acceptable levels;
- (b) the actions needed to implement these measures;
- (c) who is responsible for implementing each of these measures;
- (d) how community consultation will be incorporated in the process;
- (e) a monitoring plan to assess the effectiveness of the mitigation measures employed; and
- (f) a cost estimate of implementing the ESMP.

The ESMP should be carried out as an integrated part of the sub-project planning and execution. It must not be seen merely as an activity limited to monitoring and regulating activities against a pre-determined checklist of required actions. Rather it should be used as a dynamic management approach, dealing flexibly with environmental and social impacts, both expected and unexpected, as sub-project implementation proceeds. For those sub-projects requiring an ESMP, it should be a part of the Contract Document.

The ESMP will be prepared by the developer or contractor, and reviewed and approved by the responsible Union PMO.

8.6.3. Resettlement Policy Framework (RPF) and Resettlement Action Plan (RAP)

A Resettlement Policy Framework (RPF) (Annex 11) has been prepared for the NEP in the event that an activity carried out under the project leads to

- any persons needing to be resettled or relocated,
- the acquisition of land,
- the loss of private assets,
- the temporary occupation of private land, or
- the loss of income or any portion of people's livelihoods, either permanent or temporary.

The RPF describes procedures and requirements to assess these impacts, and the types of safeguards measures that would be required. Voluntary donations of land are permitted under the project under strict conditions. The protocol and method of reporting these donations is provided in the RPF and separately in Annex 12. If compensation is required for any of the permanent or temporary losses of land, assets, or income/livelihoods, either a Resettlement Action Plan (RAP) or an abbreviated RAP will be prepared. The developer or contractor will prepare the RAP with guidance from the safeguards team of the responsible PMO. An indicative outline for an abbreviated RAP is presented in Annex 13)

Contracts should not be signed for the sub-projects or grid extension section covered by the RAP until all compensation or other entitlements are agreed to in writing by the project affected persons and included in the final RAP, which is then provided to the responsible PMO for approval. Acquisition of land, compensation payments, and any other entitlements should be done only after the PMO has approved the final RAP with the compensation agreements included.

If land has already been purchased by the developer or contractor, including purchases prior to preparation of the project proposal, the responsible PMO will undertake a due diligence assessment and report to assess if land acquisition has followed national requirements and is consistent with the objectives of the World Bank Involuntary Resettlement Safeguard (OP 4.12). The PMO will then prepare an action plan for the developer to address any gaps identified in the due diligence process.

8.6.4. Indigenous Peoples Plan (IPP)

An Indigenous Peoples Plan (IPP) will be required for grid extension activities and mini-grid subprojects where there are ethnic minority communities and other vulnerable groups. An Indigenous Peoples Planning Framework (IPPF) is provided as Annex 9, with an indicative outline for an IPP provided as Annex 10.

A key requirement of the World Bank safeguard on Indigenous People (OP 4.10) is to obtain broad community support¹⁴ from ethnic minorities (as identified under the project) for all project activities and impacts affecting them. This includes both potentially harmful impacts as well as those deemed

¹⁴ Broad community support means that ethnic minority community has indicated its support or consent as a group through its leaders or other recognised representatives. There can be broad community support even if some individuals object to the project; however, those individuals should not be a significant portion of the community.

positive by the project, since people from another culture may have a different sense or belief of what might benefit them or not.

Consultations held with ethnic minority organisations during preparation of the NEP did not reveal any opposition to the project, as improved electrical services are widely in demand in all states and regions of the country. Even so, as each community is identified as affected by a mini-grid sub-project or a segment of the grid extension, obtaining their free, prior and informed consent is required before that activity can be carried out.¹⁵ Consent or support of the activity should be obtained, rather than only a lack of opposition.

The IPP includes, among other information:

- definition of the affected ethnic minority groups (or other vulnerable group) in the project area of influence, with an assessment of the lands and resources of these groups and how they would be affected by the project
- summary of disclosures to and consultations with the groups, including any concerns they raise, and the responses to those concerns
- framework for further consultations during implementation
- measures to insure the ethnic minorities receive social and economic benefits in a manner that is culturally acceptable
- financing plan for the IPP
- description of the grievance redress mechanism available to the ethnic minorities
- the proposed monitoring and evaluation measures for the IPP and reporting

With the great number of ethnic minorities in Myanmar with diverse cultures and languages, and with many communities having a mix of ethnic groups, special consideration is needed to assure the ethnic minority groups are informed and consulted in a language understood by all, and using methods that are culturally appropriate and understandable to the group.

¹⁵ Free, Prior and Informed Consent (FPIC) is a specific right that pertains to indigenous peoples and is recognised in the United Nations Declaration on the Rights of Indigenous Peoples (UNDRIP), of which Myanmar is a signatory. “Free” means that the consultations are held and the consent is given voluntarily and without coercion, intimidation or manipulation of the ethnic community. “Prior” means well in advance of an activity being initiated, usually at the scoping or planning stages. “Informed” means that the people are provided with the information needed to make decisions, and that the information is presented in the language they understand and in a manner that is culturally acceptable to them. The community must be able to make decisions through their customary processes. It is also understood that they can withdraw their consent at any stage, and so the process of consultation must continue through planning and implementation.

8.6.5. Initial Environmental Examination (IEE) and Environmental and Social Impact Assessment (ESIA)

Under Myanmar's current Environmental Impact Assessment Procedures, all typical NEP subprojects do not require either an Initial Environmental Examination (IEE) nor an Environmental Impact Assessment (EIA) or ESIA. For power lines, only those ≥ 115 kVA and < 230 kVA over 50 kilometres length and those of ≥ 230 kVA of any length require an IEE none of which are included in the Project's Grid Extension component. For the off-grid projects, none of the technologies being used require an IEE at the expected level of production, with the possible exception of hydropower projects producing ≥ 1 MW. Other technologies under NEP do not require an IEE if less than 5 MW (wind, heat) or less than 50 MW (solar, waste), all of which are well above the levels of power production by any of the mini-grid sub-projects.

Even so, the responsible PMO can require an IEE if potential impacts on natural habitats, ethnic minorities or vulnerable groups are categorized as high-risk during the scoping process, even if other potential impacts are classified as low- or medium-risk. In exceptional cases an ESIA may be required by the responsible PMO if potential impacts are unavoidable and severe without adequate mitigation measures. Some cases where an ESIA might be required are a power line traversing a sensitive biodiversity area, a sub-project located near the habitat of a vulnerable species, or a sub-project possibly affecting lands and other resources which an ethnic minority community depends on for their livelihood.

If an IEE or ESIA is deemed necessary, the developer or contractor will prepare (or engage a consultant to prepare) the document under the procedures outlined in the Government of Myanmar's Environmental Conservation Rules (adopted since 2014). Having been produced with the assistance of the Asian Development Bank (ADB), the IEE and ESIA procedures of the GoM are considered largely equivalent with the requirements of multilateral development banks such as the World Bank. The IEE or ESIA would have to be approved by the Ministry of Natural Resources and Environmental Conservation (MONREC) before the sub-project can be approved and funded by the Project.

9. Monitoring and Evaluation

A number of implementing agencies will have monitoring and evaluation responsibilities during the implementation of the Project. The Union PMO has overall responsibility for NEP Environmental and Social performance, including monitoring the implementation of the ESMF and subsequent preparation, implementation and monitoring of Environmental and Social Safeguards Instruments for sub-projects.

During project implementation, the Union PMO (either directly or through the District or Township PMOs) will check with local environmental authorities to determine if the project implementation is meeting all safeguard requirements specified in this ESMF and sub-project safeguard instruments (e.g. ESCoP, ESMP, RAP, IPP), as well as those required by national legislation. The Union PMO (either directly or through the District or Township PMOs) will also perform supervision site visits during the construction and operations phases of the sub-projects to confirm that environmental and social safeguards instruments are being adequately implemented. The Union PMO will prepare a site visit report which will include the environmental and social management issues reviewed during the supervision site visit.

The Union PMO will regularly inform the Project Steering Committee and World Bank Task Team regarding the status of ESMF implementation and provide an overview report of the implementation of sub-project environmental and social safeguards instruments. The PMOs will prepare quarterly and annual reports on the key steps, outputs and results of the environmental and social management actions taken to support the implementation of the ESMF and the sub-projects. The PMOs will inform the Project Steering Committee and World Bank Task Team of any shortcomings in the implementation of the ESMF and of any circumstances or occurrences that could have a materially adverse impact on the environmental and social performance of the project that go beyond the impacts envisioned and managed through the processes outlined within this ESMF.

9.1. Monitoring plan for a subproject

The primary objective of environmental monitoring is to verify the absence of or record environmental and social impacts resulting from the subproject activities and to ensure compliance with the "mitigation measures" identified earlier under the ESCoP and the ESMP, RAP and/or IPP, in order to prevent or reduce adverse impacts and enhance positive impacts from project activities.

Monitoring during construction:

During implementation of all subprojects, the PMOs will be responsible to monitor and make sure that the environmental and social mitigation/enhancement measures (including health and safety measures) outlined in the ESCoP and the ESMP, RAP and/or IPP, for the particular subproject are being implemented.

Apart from general monitoring of mitigation/enhancement measures and health and safety protocols (as outlined in the ESMF and Tender Document), important environmental parameters to be monitored during the construction phase of the subprojects include noise level, water quality, drainage congestion, and traffic problems. However, the requirement and frequency of monitoring would depend on the type of subproject, the anticipated impacts and the field situation, and will be determined by the selection of the ESCoP and, if required, the preparation of the ESMP

Routine monitoring work will be done by the respective PMO to ensure that:

- All personnel at work sites shall be provided with protective gears like helmets, goggles, boots, etc. Workforce, likely to be exposed to noise levels beyond regulatory stipulated limits, shall be provided with protective gears like earplugs etc. and regularly rotated.
- Dust suppression measures like sprinkling of water shall be ensured at all operations areas.
- Construction camps, if needed, shall have health care facilities and all construction personnel shall be subjected to routine vaccinations and other preventive / healthcare measures.
- The work and campsites shall have suitable facilities for handling any emergency situation like fire, explosion, electrocution, etc.
- All areas intended for storage of hazardous materials shall be quarantined and provide with adequate facilities to combat emergency situations. All required permits for storage of inflammable / hazardous materials are to be obtained.
- The construction workers, supervisors and engineers shall be properly trained and with sufficient experience.
- The operational areas shall be access controlled and entry shall be allowed only under authorization.
- Construction camps, if needed, shall have in-house community / common entertainment facilities.
- The work supervisors conduct regular checks on ESCoP and ESMP requirements.
- Measures outlined in the RAP and/or IPP, if any, are implemented as described in the plans (RAPs and IPPs will also include specific monitoring arrangements).

Sub-projects with medium- or high-risk impacts will require more stringent monitoring. Table 9.1 provides a general example of the arrangements for such a sub-project.

Table 9.1: Guidelines for monitoring of environmental parameters during construction for subprojects with medium/high risk impacts

Monitoring Parameter and Scenario	Monitoring Frequency	Resource Required and Responsibility
Noise Level	Once every week, particularly during operation of heavy equipment	Contractor, under guidance of PMOs
Surface Water Quality (pH, BOD ₅ / COD)	Once during construction period (at a location downstream of the work area)	Contractor, under the guidance of PMOs
Appropriate Disposal of Chemical Oil	Once a week during operation period as and when needed	Contractor, under the guidance of PMOs
Visual observation of drainage congestion within around subproject location	Monthly	Contractor, VEC staff
Visual observation of traffic within around sub project location Occupational health and safety of project personnel (also includes general health, water supply and sanitary provision, etc.)	Once a week, when drainage / traffic congestion suspected Once a week, and as and when needed	Contractor, under the guidance of PMOs
Monitoring and surveillance for prevention of fire hazard	Once a week, and as and when needed	VEC staff under the guidance of

Monitoring during operation

During operational phase, monitoring of environmental parameters would be required for the subproject.

10. Estimated Budget for Environmental and Social Mitigation and Management

The indicative cost estimate for basic implementation of the environmental and social components under the ESMF is approximately USD 1,800,000. This amount is an estimate and may differ from the final cost under this ESMF.

The Contractor carrying out the construction of the subproject is assumed to include the cost of compliance with the ESMF in the bid or project proposal. These estimates should be prepared for all mitigation and monitoring measures required under the ESCoP, and proposed in the ESMP, RAP and IPP when required.

Costs of implementing sub-project safeguard instruments, including monitoring activities, needs to be estimated by the developer or contractor as a part the sub-project budget, of the preparation of the ESMP/RAP/IPP. Many of the activities to be carried out as a part of ESMP/RAP/IPP would not involve any additional direct cost e.g., employing local work force, where appropriate; keeping subproject vehicles in good operating condition; scheduling deliveries of materials/ goods in off-peak hours; good housekeeping, avoiding spills; prohibiting use of fuel wood for heating bitumen; etc. On the other hand, a number of activities would require additional cost. Environmental and social monitoring during both construction and operational phases would involve direct cost.

At the same time, a number of mitigation measures (including health and safety measures) would also require additional cost; these include installation of septic tank/sanitary latrine/portable toilets, installation of health and safety signs, awareness documents (signs/posters), water sprinkling on aggregates and unpaved surfaces, traffic control (e.g., deputing flagman), traffic light, plantation, and protective gear. Costs for compensation for land acquisition and related impacts, as defined in the RPF, will be funded by the project implementer (MOEE or its utilities for grid extension, private developers for mini-grid subprojects) in agreement with the respective local authorities depending on the type of subproject; and this should be included in the subproject budget.

Funds can be shifted between categories of the ESMF budget as needed.

Table 10.1: Estimated Budget for ESMF Implementation

Activity	Cost Estimate (USD)	Remark
Safeguard Capacity Building, including training	300,000	
Translation and Publication of ESMF material for implementation	150,000	
Screening, Monitoring of subproject safeguards instruments	300,000	
Baseline Studies (air, water, data collection, measurements, social surveys), and consultations with local communities (not including those to be done by private contractors)	300,000	
TA and Consultants	600,000	
Contingency (10%)	165,000	
TOTAL ESTIMATED BUDGET	<u>1,815,000</u>	

11. Community Engagement, Consultation and Public Disclosure

The GoM emphasizes the importance of “good governance, clean government” and is taking a series of actions to improve participation, public consultation and disclosure. However, implementation of these will rely on strategies, legislation and procedures that are still to be prepared and passed. The Project will follow World Bank Group Safeguard Policies for participation, consultation, and disclosure concerning safeguard aspects of the Project as described in this ESMF, including particular procedures included in the IPPF and RPF.

The Project aims at achieving meaningful consultation that is a two way process in which beneficiaries provide advice and input on the design or the proposed subproject that affect their lives and environment. Meaningful consultation shall promote dialogue between government, communities, NGOs and implementing agencies to discuss relevant aspects of the Project and its subprojects. Consultation is an on-going process and will be carried out both during subproject preparation and implementation. Consultations with project affected people have been undertaken as part of preparation of the NEP and will continue throughout project implementation (see below and Annex 9 on the IPPF).

The Project supports decision making by allowing the public access to information on environmental and social aspects of the project, as included in World Bank Safeguard Policies, including for Environmental Assessment, Involuntary Resettlement and Indigenous Peoples. This ESMF and the site specific ESCOPs/ESMPs/RAPs/IPPs prepared for the subprojects will be disclosed to the public. Safeguard instruments should be made available to communities and interested parties at accessible locations, including through local government authorities – district and township level MOEE or utility offices, district and township DRD offices, and Township General Administration Department (GAD) offices – and in the communities themselves before works may commence. They should be made publicly available in a manner understandable to affected people, which may include local languages if needed. The IPP, where prepared, should also be made available to the affected ethnic minority communities in places, and in a manner and language that are accessible to them.

The PMOs and partners will also provide periodic reports to the affected communities and other relevant stakeholders on the implementation status or any modification to environmental and social management plans. The PMOs will use a variety of communication tools that will be included in the communication strategy and could include infographics, leaflets and frequent questions and answers to be distributed among different stakeholders, a phone-line to the PMOs, etc.

In addition to consultations carried out regarding this ESMF, the Project will consult communities where grid and off-grid components are to be implemented. The objective of the community consultation is to encourage potential beneficiaries to participate in the project, as relevant, by informing them of various benefits, and ensuring that they are also aware of potential negative environmental and social impacts, mitigation measures, and the contacts for the GRM, VEC and Safeguard Focal Point within the MOEE and DRD PMOs.

Community engagement and consultation is embedded in the Project and is considered a strategic part of its Results Framework. As part of its citizen engagement (CE), the PMOs will consider the number of consultations and the average number of beneficiaries and share of vulnerable people participating in each public consultation for grid and of grid electrification as

an indicator of success. In the Project’s results framework the “number of villages with at least one public consultation was held” is a key indicator. For many subprojects more than one public consultation would be required. The CE is designed to enhance project performance as well as help address several important issues, including gender, inclusion, and achievement of maximum connection (for grid and mini-grid, and maximum adoption of SHS for the off-grid). Topics of the general consultation (in addition to any required consultations concerning safeguards) will include:

1. Informing and explaining to villages about the project, connection cost, electricity tariff;
2. Canvassing and/or soliciting for maximum connections from villagers and possibly take applications from villagers for electricity connections;
3. Gather information to explain who do not sign up for connection, whether they are from ethnic minorities or other vulnerable groups (religious minority, poor, elderly, female headed households, etc.) and why (to gather information to identify individuals in need of assistance, how much assistance villagers will need, and to propose programs like Power to the Poor which aims to provide financial and other assistance to vulnerable households);
4. Educate villagers, both men and women, on the dangers of electricity and safe practices, proper house wiring (many utilities have safety standards for house wiring), efficient use of electricity, how to select efficient lighting and home appliances;
5. For SHS and the RBF Off-Grid Solar sub-projects, inform villagers, both men and women, how the program works, how much the solar home system costs, the types of battery used, the appropriate size of system for their family, which lighting and appliances are the best fit for the system, how to maintain and operate the SHS, safety concerns, and quality assurance and guarantees; and
6. Gender sensitive consultations to educate women on the use of electricity for cooking (such as electric rice cookers), empowering women by providing information and educating women on electricity tariffs, and efficient electric appliances to reduce monthly electricity bills.

The key stakeholder groups identified during project preparation and consulted when preparing the original ESMF are presented in Table 11.1.

Table 11.1: Key stakeholder groups

Government and regulatory agencies	DRD, ESE, States/Regions, Districts and Townships.
------------------------------------	--

Private sector companies and social enterprises	Private sector companies with the skills and capabilities, and interest, in implementing subprojects. This may include both national and international companies and, for the off-grid component, may also include social enterprises.
Non-government organizations	National, regional and local civil society and Non-government organizations, including environmental and ethnic minority organizations.
Local stakeholders	Community-based organizations (CBOs), Municipal and district-level committees, unions, and other local groups.
Academic and research institutions	Environmental research groups, universities, and technical institutes.
Beneficiaries and affected communities and households	Project beneficiaries, both men and women, will be consulted at a community level during the preparation of subprojects. In addition, potential subproject affected households will be consulted on the potential impacts and mitigation measures. Particular attention will be made to include the poor, female-headed households, widows and other vulnerable households and groups to enhance their benefits and avoid or mitigate adverse impacts. For the mini-grid subprojects, consultations will continue as needed throughout implementation.

Ethnic minority communities	If projects are planned in areas with ethnic minority communities, a process of free, prior and informed consultations will be undertaken with those ethnic minority communities in the project area of influence (see IPPF, Annex 9)
Development Partners	Other development organizations engaged in the energy sector in Myanmar

During the process of preparing the ESMF the *PSIA to inform the ESMF* involved stakeholder consultations. More than 20 organizations based in Yangon were consulted; many of which were CSOs with a specific focus on ethnic minorities, land and/or gender. In addition, key resource persons identified as those that could provide insights relevant to ethnic minorities were interviewed. An early consultative meeting was held on January 30, 2015 in Yangon with civil society organizations, including some ethnic minority organizations. Background documentation on the proposed project was prepared in Myanmar and English and provided in advance of this meeting. In addition, meetings and discussions were held with community leaders and CSOs in Chin and Shan States during the PSIA field visits.

The first draft of the ESMF and Preliminary PSIA were disclosed in English and Myanmar on May 5, 2015 prior to public consultations. Public consultations were held in Mandalay on May 14, in Taunggyi (Shan State) on May 16 and Yangon on May 18. See Annex 14 for more details on the consultation process during preparation of the Project and the ESMF.

The draft of this revised ESMF was disclosed in English and Myanmar on xxxxxx 2018. Various channels were provided, including social media, for comments to the MOEE and DRD PMOs for one month after disclosure.

12. Grievance Redress Mechanism

A grievance redress mechanism (GRM) was prepared for the Project to create an enabling environment for affected communities and individuals to raise complaints to implementing entities in regard to the preparation and implementation of subprojects. It aims to enable the PMOs to receive and facilitate resolution of the specific concerns of affected communities and project participants regarding project environmental and social performance. The GRM aims to resolve concerns promptly, in an impartial and transparent process tailored to the specific community, and at no cost and without retribution to the complainant/s. The GRM is based on the following six principles: fairness; objectiveness and independence; simplicity and

accessibility; responsiveness and efficiency; speed and proportionality; participatory and social inclusion. While still following the principles and processes described below, the respective PMOs have since established GRMs according to their institutional arrangements and using available technologies.

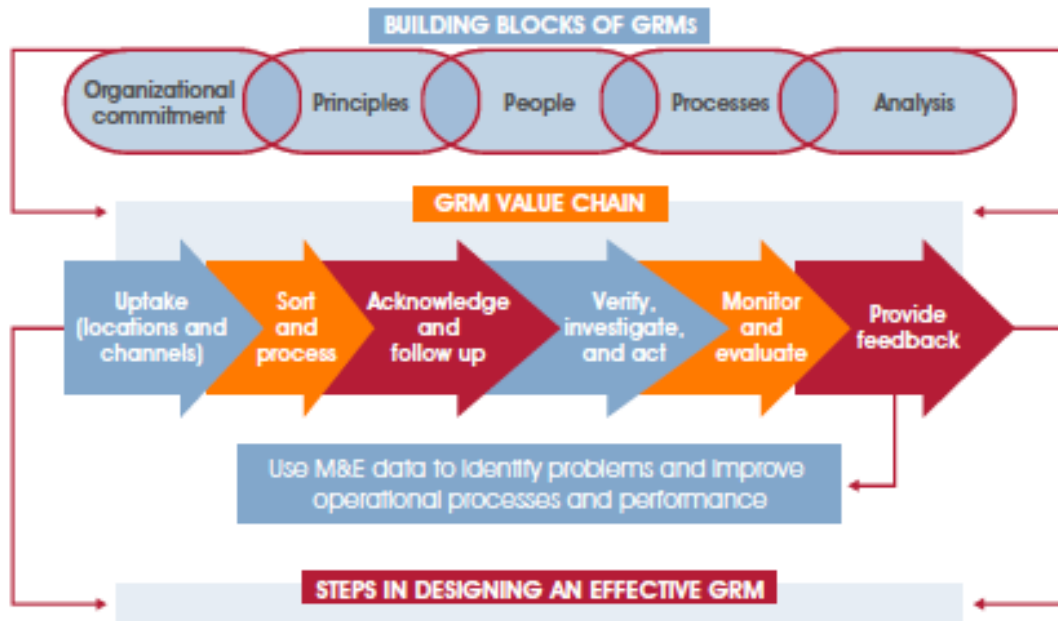

Source: World Bank, Feedback Matters: Designing Effective Grievance Redress Mechanisms for Bank-Financed Projects p. 3

The GRM will be communicated to different stakeholders. It is intended that information about the GRM be disseminated widely in meetings and through pamphlets and brochures in Myanmar language, and ethnic languages as needed/relevant. Specifically, information will be provided about how and where to lodge complaints/grievances. Villagers will be encouraged to seek clarification or remediation through the mechanism if they have any questions or complaints/grievances.

Sub-project specific safeguard instruments (ESMP, RAP, IPP) will describe the GRM in detail based on the following procedures for addressing grievances:

Stage 1: An initial stage, within the local village or township level, in which any person/s aggrieved by any aspect of the Project can lodge an oral or written complaint/grievance to the local Village Electrification Committee (VEC) or implementing partner/operator. The VEC or implementing partner/operator should keep a written record of complaints/grievances raised by villagers and their resolution; they should inform the District DRD or MOEE PMO of such complaints and resolutions.

If the complaint cannot be resolved within 15 days of receipt between the aggrieved person/s and the VEC or implementing partner/operator, it should be escalated to the second step of the process.

Stage 2: If the aggrieved person is not satisfied with the outcome of the initial stage, she/he/they can lodge the complaint to the District DRD or MOEE PMO. During the dialogue

process the issues raised will be reviewed, and the parties will agree upon actions for resolution. The dialogue will seek a resolution to the grievance as long as all the parties involved are amenable to the process. The District DRD or MOEE PMO should keep a written record of complaints/grievances raised by villagers and inform the State/Region and National PMOs of such complaints.

If the complaint cannot be resolved within 15 days of receipt between the aggrieved person/s and the District DRD or MOEE PMO it should be escalated to the third step of the process.

Stage 3: If the aggrieved person is still dissatisfied following review by the District DRD or MOEE PMO, the case should be referred to the respective State/Region and/or National PMOs. The State/Region and/or National DRD should keep a written record of complaints/grievances raised by villagers and inform the NEEC (or equivalent body when established) and World Bank of such complaints.

If the complaint cannot be resolved within 20 days of receipt between the aggrieved person/s and the District DRD or MOEE PMO, the aggrieved person/s may proceed to legal proceedings in accordance with the GoM's laws and procedures.

The VECs and respective PMOs will keep a record of all complaints received, including a description of issues raised and the outcome of the review process. A grievance database template will be prepared to ensure that all key information is captured. Written feedback will be provided to aggrieved persons or parties to the dispute throughout the GRM process.

For the off-grid component, the DRD has set up a GRM using social media. FaceBook is by far the most popular social media in Myanmar, used by people on their mobile phones in even the most remote areas. The DRD Communications and Grievance Team has set up a FaceBook page to provide information to the public and for people to contact the project through Messenger. This is provided as an alternative focal point for grievances.

Regular monitoring of the effectiveness of the GRM will be included in the monitoring and evaluation (M&E) approach for the Project. In undertaking the regular M&E activities, the following questions will be raised:

- Does the project have clear, formal, and transparent internal mechanisms and rules for addressing grievances?
- Do project officials responsible for grievance redress have the authority to take or demand remedial action?
- Are officials responsible for grievance redress obliged to take action on all grievances?
- Do project-affected people feel that they can lodge grievances without fear of retaliation?
- Are project beneficiaries aware of their right to file a grievance and of the grievance redress procedure in general?
- Are there internal processes in place to record, track, and monitor the grievances and the action taken on them?
- Does the GRM provide timely feedback (written or otherwise) to the petitioner on actions taken?
- Is there an appeals process in place that GRM users can access if they are not satisfied with how their grievance has been resolved?

Grievance redress monitoring indicators may include:

- Number of complaints/ grievances registered.
- Percentage of grievances resolved.
- Percentage of grievances resolved within stipulated time period.
- Time required to resolve complaints (disaggregated by different types of grievances).
- Percentage of complainants satisfied with response and grievance redress process.
- Percentage of project beneficiaries that have access to the GRM.

13. Capacity Building and Training Plan

Overall capacity for environmental and social management within the PMOs needs to be developed. Although both DRD and MOEE have recent experience implementing a World Bank-financed projects, there is limited experience within the Ministries in environmental and social management and World Bank safeguard policies. Furthermore the relatively junior engineering staff assigned to the safeguards teams has not been drawn from the other World Bank projects, and so they are becoming familiar with safeguards policies and procedures only since they have started to work on this project.

Delays in setting up the safeguards teams and in engaging national and international experts make the need for rapid capacity building more urgent, as many project activities have been implemented or are will into the planning stages. Fortunately the activities thus far have been generally low risk and with potentially low environmental or social impacts.

Even so the lack of effective safeguards screening and monitoring is itself highly risky for the project, should problems arise that could have been avoided or mitigated with a well-functioning safeguards procedure. This is especially so as project activities increase in pace and scope. The off-grid mini-grid subprojects are probably the most likely to have more significant environmental and social impacts, with their greater infrastructure, longer periods of construction, and many more workers staying for longer time in villages. As of mid-2018, 6 mini-grid subprojects have been implemented, while another 6 are well along the planning stage. But dozens more will be built in the next 2-3 years, many in more remote areas peopled with a diverse mix of ethnic minorities, and in more difficult terrain.

For these reasons, Institutional Strengthening and Implementation support together with a structured Capacity Building program are required to assist the PMOs in implementing the ESMF and providing safeguard related outcomes in a timely manner.

PMO Institutional Strengthening and Implementation Support

Target Groups for Capacity Building

Safeguards Teams: The main targets for the capacity building activities must be the safeguards teams of the Union PMOs. They are the focus for the safeguards efforts of the project, and the other target groups will be trained and learn through (and by) the safeguards teams.

They must become sufficiently knowledgeable of the safeguards policies to be able to screen and guide the sub-projects in identifying environmental and social risks and in the practical application of the safeguards instruments. It is not enough to know the policies and instruments; but they also need to learn how judge where, when, and how to apply the instruments, and to guide those implementing the subprojects in identifying, planning and implementing mitigation measures. They need to know how to conduct consultations, and to train others how to conduct consultations, how to include women and vulnerable groups, and especially how to conduct consultations with ethnic minorities.

Other PMO Units: The safeguards teams can help build capacity of other PMO units, and in particular those involved with planning, designing, supervising, and monitoring field activities, by helping those units understand the role of the safeguards in avoiding, or at least reducing problems. Work by the safeguards teams can then become integrated more easily into the activities of the other PMO units, such as sub-project screening and planning, field visits, monitoring, and training.

District and Township Officers and Engineers: The DRD township officers and engineers, and the township engineers for the MOEE utilities, have key roles throughout the sub-projects. They do the environmental and social screening or initial reviews and approval if others screen, and they do most of the monitoring of compliance with the safeguards during construction and installation works. As such, they should know the reasons for the questions being asked in the screening, understand the consultation process, and understand the issues covered in the ESCoPs, ESMPs, RAPs, and IPPs. District level officials also need to understand the purpose and application of safeguards, as they are the direct supervisors of the township offices and also involved at an appellate stage of the grievance redress mechanism.

Private Sector Participants: Sub-project developers for the mini-grid systems are responsible for screening, carrying out consultations, identifying potential environmental and social issues, proposing mitigation measures, and if necessary preparing ESMPs, RAPs, and IPPs with the assistance of the safeguards team. They are also responsible for compliance with the safeguards by following the conditions of the ESCoPs and the other plans. They need to be trained in the use of and understand the reasons for these safeguards instruments and processes. Other contractors and private companies or social enterprises involved in the project may also be involved in screening, and will certainly be responsible for compliance with the safeguards.

VECs and Other Villager Leaders: In addition to learning through consultations about potential environmental and social impacts and their mitigation through the safeguards instruments, VEC members and other village leaders from communities where additional safeguards instruments (ESMP, RAP, IPP) will need training to understand in greater detail the contents of those plans, so they can help assure that the developers, contractors, etc., are adhering to the plans and in compliance with the safeguards.

Institutional Strengthening

In order to ensure that there is adequate capacity to implement and monitor the ESMF, environmental and social experts will be hired as members of the Union PMOs. The specific tasks carried out by the Environmental and Social Safeguard Staff with support from the experts will include:

- Supervise sub-projects progress as it relates to compliance with the ESMF guidelines, resolving implementation bottlenecks, and ensuring that overall project implementation proceeds smoothly;
- Preparing annual work programs and budgets linked to the implementation of ESMPs and/or with a focus on environmental and social management aspects;
- Reviewing and assessing environmental and social information relevant to the project and accounts (i.e., environmental and social monitoring by township offices and independent verification assessment reports);
- Ensuring that the implementing bodies are supported adequately and that they adhere to the principles of the project, specific to compliance with the ESMF guidelines;
- Verifying, through field trips, compliance of service providers with ESMF; and
- Responsibility for the organization and provision of training sessions, including a training plan and its modules, in environmental and social screening and environmental and social management and also involuntary resettlement and indigenous peoples safeguard policies.

The environmental and social experts engaged by the NEP will also:

- Contribute to the daily PMU Safeguard Team operations, resolving implementation bottlenecks, and ensuring that overall project implementation proceeds smoothly
- Contribute to the preparation, review and implementation of adequate safeguards instruments (e.g. Terms of Reference, ESIA, ESMP, RAP, IPP) as per the ESMF
- Supervise and monitor sub-projects progress as it relates to compliance with the ESMF and provide technical inputs and quality control of Environmental and Social Monitoring reports, including timely information on the implementation of Environmental and Social Management Plans and status of analytical work
- Contribute to design and implementation of Safeguard Related Capacity Building Program, Technical Assistance and Analytical work including Environmental and Social Baseline, Surveys, and others

- Contribute to the PMOs Stakeholder Engagement, including grievance mechanism, and support in the implementation of related activities on stakeholder and community engagement, including grievance mechanisms
- Contribute to the preparation of annual work programs and budgets linked to the implementation of ESMPs and/or with a focus on environmental and social management aspects as well PMOs continue Capacity Building needs assessment and Program
- Organize and participate in Project-related missions and workshops

Efforts will be made to ensure that both male and female staff of the relevant agencies and communities have equal opportunity to participate in the capacity building and training support from the Project. To the extent possible, gender disaggregated data will be collected. Efforts will also be made to ensure that ethnic minority representatives are included among those trained.

Implementation Support

It is envisioned that the Union PMO safeguards teams will need on the job training and periodic assessment of their ability to carry out their tasks. Consultants should be engaged to provide this support, to work with the safeguards teams to ensure sound safeguard management and compliance with the requirements of the ESMF. The specifics of the consultancies will be further developed and modified during implementation as needed but it is envisioned that it will cover the following activities:

- Provide on the job training to PMOs Safeguard Units concerning review, preparation and implementation of adequate safeguards instruments (e.g. Screening and Scoping Reports, ESCoP, ESMP, RAP, IPP) and their preparation;
- Work closely with the PMOs to clarify subproject cycles including safeguards requirements at each stage, from identification to monitoring, including rules and responsibilities, procedures, and clearances from the World Bank and the GoM.
- Assist the PMOs in the review and approval of subproject safeguard instruments.
- Liaise closely with the PMOs in the design and implementation of training, knowledge exchanges, and mentoring. This will include either directly providing in house training as well as drafting TOR and technical specifications to contract specific capacity building initiatives, where needed;
- Provide guidance and quality control for the reporting process during early stages of the project;
- Advise the PMOs on Stakeholder Engagement, including assessing the grievance redress mechanism, and support in the implementation of related activities;
- Support in organizing and participating in missions, field trips, seminars and workshops; and Safeguard-related activities as required by the PMOs.

Additional Staff

As the number of subprojects increases in coming years, the safeguards teams may find themselves overstretched. Even though most subprojects will only require the initial screening and application of the ESCoPs, reviewing and assessing the screening, the consultations, proposed mitigation measures, and monitoring compliance with safeguards and the ESCoPs will be a sizeable responsibility. Add to that their work to assess the need for and help prepare and review additional safeguards instruments (ESMP, RAP, IPP) for some the subprojects, train local staff, village leaders, and participating private companies, and their reporting responsibilities, it is evident the safeguards teams may well need additional help. It is suggested that others from within the project who have been trained about and understand the safeguards process, either from within NEP or from other World Bank (or ADB) supported projects, be assigned to assist the team as needed.

Safeguards Capacity Building Program

For the PMO Safeguards Teams

The highest priority must be given to capacity building of the Union PMO safeguards teams, as they are crucial to successful implementation of the entire safeguards program. Much of this requires good comprehension of English, as most materials on safeguards are in English, training by World Bank and other outside experts is in English, and reports to the World Bank need to be in English. The team needs to be able to take these lessons from international training and documents, then process and apply them to local situations, and then train local staff, developers, and village leaders. This requires a level of English comprehension that the teams do not yet have. It is therefore strongly recommended that the Union PMO safeguards teams be given regular English lessons as part of their capacity building.

The safeguards teams also should continue to receive training to become sufficiently familiar with the safeguards policies, and with the practical application of those policies in the NEP. They need to know why the screening questions are being asked, so they can assess the responses adequately, and then how, where, and when (and how rigorously) the various safeguards instruments should be applied.

They need continued training in how to conduct village consultations, and involve women and vulnerable groups in the process (in the DRD, this is to be done together with the PMO Communications and Grievance Team). Additional training would be needed on the consultation and decision making processes with ethnic minorities.

They need continued training in the preparation and application of the safeguards instruments, including

- What is the purpose of the ESCoP and how should it be modified as needed;

What are the purposes of the ESMP, RAP, IPP; when and where should each of these be applied; and how are they prepared; and

- How to monitor compliance with the safeguards and in particular monitoring implementation of each of the specific plans.

Other PMO Units

While other key staff of the PMO might participate in training from outside experts, to help raise their awareness of the safeguards policies and application, most the capacity building of the other PMO units should be done informally by the safeguards team. Whether over lunches or in informal discussions or workshops, the safeguards team should strive to help the other units understand the role of safeguards and how the work of the safeguards team can best be integrated with that of the other units.

District and Township Officers and Engineers

The safeguards team should provide training to the local level officers and engineers, so they will understand the role of safeguards, be able to use the safeguards instruments (screening forms, others as needed), the importance of monitoring and how best to monitor, and the grievance mechanism (as the township offices are one of the first contacts).

Some of this training can be done through formal workshop and training sessions, while the rest is best done through on-the-job support from the safeguards team, whether through field visits to sub-project sites or discussions in the township offices.

Private Sector Participants:

Training will be provided to private sector participants at crucial stages in their involvement.

MOEE contractors will be trained on the ESCoP and other relevant safeguards policies for their work after they have won the bids for contracts, but before they begin any construction or installation works

SHS contractors will be trained on the ESCoP and other relevant safeguards policies for their work after they have won the bids for contracts, but before they begin installation.

Companies or social enterprises joining the RBF Off-Grid Solar sub-project will be trained after they have joined the program, but before they begin sales.

Developers of the mini-grid subprojects will be trained in at least 2 stages: (1) after the call for proposals, to understand the consultation process and how to work with villagers (with additional training for those who will work with ethnic minorities), to understand how to include environmental and social matters in their project proposals, and to be informed of the safeguards process throughout planning and implementation; and (2) after review of the pre-

feasibility studies, but before preparation of the feasibility studies, to understand the requirements of the ESCoP, and to learn how to prepare and implement other instruments (ESMP, RAP, IPP) as needed. Special training may be required for those working with ethnic minorities that will require an IPP.

VEC Members and Other Village Leaders

Training will be given to VEC members and other village leaders where the DRD mini-grid subprojects are being built, to help them understand in greater detail the safeguards instruments and the application of the ESCoP, to help assure that the developers, contractors, etc., adhere to the plans and are in compliance with the safeguards. Additional training would be needed to VEC members and other village leaders for those subprojects where any additional safeguards instruments are needed (ESMP, RAP and/or IPP) so they will understand in greater detail the contents of those plans, and help assure that the developers, contractors, etc., adhere to the plans and comply with the safeguards.

Training Schedule

To meet some of the needs described above, the DRD PMO safeguards team with assistance from the national safeguards expert prepared a list of training activities they will conduct in the coming months, presented below in Table 13.1

Table 13.1 Draft Training Plan for 2018-2019 Prepared by DRD PMO Safeguards Team

Training Needs	Target Stakeholders	Target Timeline	Status
Environmental & Social Management Framework and related documents	DRD Safeguard Team (Union)	July, 2018	
Environmental and Social Codes of Practice & Screening Forms			
Project procedure concerning safeguard guidelines	DRD Staff (State & Region)	June, 2018	Completed
Project procedure concerning safeguards guidelines and monitoring	DRD Township Engineer	October, 2018	
Environmental & Social Safeguard Compliance	Mini-grid Developer	September, 2018	
Introducing Safeguard Screening Forms and ESCoPs (mini-grid)	Mini-grid Developer	September, 2018	
Workers' Safety & Working Conditions	Mini-grid Developer		
Introducing Safeguard Training and ESCoPs (SHS)	SHS Developer		

Environmental and Social Safeguards Awareness Training	Communities	During Monitoring Trip	
---	-------------	------------------------------	--